

# INSTRUCTION MANUAL

Serial Number \_\_\_\_\_

**RECEIVED**  
APR 10 1973

SSCO Standards Laboratory, Inc.  
8720 Northend  
Detroit, Michigan 48237

**TYPE 3C66**  
**CARRIER**  
**AMPLIFIER**

Tektronix, Inc.

S.W. Millikan Way • P. O. Box 500 • Beaverton, Oregon 97005 • Phone 644-0161 • Cables: Tektronix

070-357

863



## WARRANTY

All Tektronix instruments are warranted against defective materials and workmanship for one year. Tektronix transformers, manufactured in our own plant, are warranted for the life of the instrument.

Any questions with respect to the warranty mentioned above should be taken up with your Tektronix Field Engineer.

Tektronix repair and replacement-part service is geared directly to the field, therefore all requests for repairs and replacement parts should be directed to the Tektronix Field Office or Representative in your area. This procedure will assure you the fastest possible service. Please include the instrument Type and Serial number with all requests for parts or service.

Specifications and price change privileges reserved.

Copyright © 1963 by Tektronix, Inc., Beaverton, Oregon. Printed in the United States of America. All rights reserved. Contents of this publication may not be reproduced in any form without permission of the copyright owner.



## CONTENTS

	Warranty
Section 1	Characteristics
Section 2	Operating Instructions
Section 3	Applications
Section 4	Circuit Description
Section 5	Maintenance
Section 6	Calibration
Section 7	Parts List and Schematics

A list of abbreviations and symbols used in this manual will be found on page 7-1.

# TYPE 3C66 CARRIER AMPLIFIER

RISETIME  $\approx 70 \mu\text{SEC}$

BANDWIDTH  $\approx \text{DC TO } 5 \text{ KC}$

## BRIDGE BALANCE

FINE  
RESISTANCE

FINE  
CAPACITANCE

25KC CARRIER



PHASE

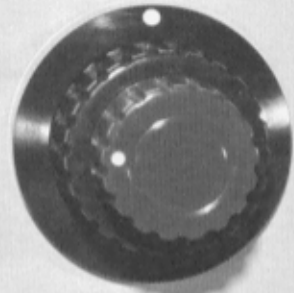

CALIBRATE  
( $\mu\text{STRAIN}$ )

EXT ARMS

EXT ARMS

-400

NORM

POSITION



VARIABLE  
 $\mu\text{STRAIN/DIV}$   
500 200

POLARITY  
FUNCTION  
INV INST NORM  
BALANCE ZERO OPERATE

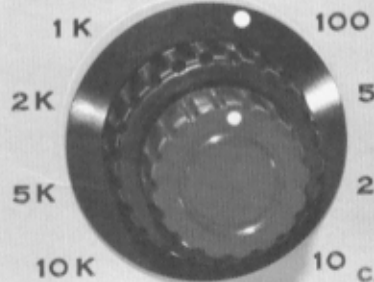

GAIN



SIG  
OUT

SERIAL

000102

SYNC  
IN

SYNC  
OUT

TEKTRONIX, INC.

PORTLAND, OREGON, U.S.A.

# SECTION 1

## CHARACTERISTICS

### General Information

The Type 3C66 Carrier Amplifier plug-in unit is designed to be used with Tektronix 560-Series oscilloscopes that will accept 3-Series plug-in units. The unit is self contained and requires no external equipment other than the transducers. Excitation voltage for the transducers is provided by the Type 3C66.

### Frequency Response

Dc to 5 kc, risetime approximately 70  $\mu$ sec.

### Carrier Frequency

25 kc.

### Mode of Operation

Suppressed-carrier amplitude modulation produced by unbalancing an ac bridge with strain gages or other transducers. A phase sensitive demodulator produces the proper direction of trace deflection.

### Strain Sensitivity

Ten calibrated steps from 10  $\mu$ strain (microunits per unit)/division to 10,000  $\mu$ strain/division. The sensitivity is continuously variable, uncalibrated, between 10 and 25,000  $\mu$ strain/division. These values apply when the unit is used with a single active strain gage with a gage factor of approximately 2. Active strain gage with a gage factor of 2 inserted into each arm of the bridge increases the sensitivity to 2.5  $\mu$ strain/division.

### Input Bridge

A 5-position switch allows selection of from zero to four external bridge arms. The zero position checks the instrument for normal operation without an external transducer. Total bridge voltage is approximately 5 volts rms. Standard resistances supplied with the instrument are 120 ohms.

### Capacitance Balance Range

Up to 250 pf across any one of the bridge arms.

### Resistance Balance Range

Sufficient to accommodate most conventional transducers.

### Phase Adjustment

Phase control has sufficient range to allow the use of either resistive or reactive transducers.

### Gage Resistance Range

For cable lengths up to 100 feet the range of useful gage resistances is from 50 ohms to over 2,000 ohms. The recommended range of gage resistances is from 120 ohms to 500 ohms.

### Gage Factor Calibration

The gage factor calibration is accomplished by adjusting the amplifier gain. No special gage factor dial is used.

### Capacitive and Inductive Transducers

A capacitive transducer with a four-arm resistive bridge results in the following useful sensitivities: 120-ohm bridge (available internally), 1.0 pf/div; 1000-ohm bridge, 0.2 pf/div.

The unit can also be used with inductive transducers; however, differential transformers designed for use at 60 cps are only partially satisfactory at 25 kc.

### Capacitance Measurement

Can be calibrated for direct reading in capacitance from 1 pf/division to a maximum value of 1000 pf/division without using a correction curve. With a correction curve, the range can be extended to 10,000 pf/division. These specifications apply when using the internal 120-ohm resistive bridge circuit. With a 1000-ohm external circuit the lower limit can be extended to 0.2 pf/division.

### Noise

Typically equivalent to 2.0  $\mu$ strain peak-to-peak.

Line-Frequency related spikes no more than 2.5 mm at 60 Hz increasing to no more than 1 cm at 400 Hz.

### Attenuator Accuracy

When the Type 3C66 is accurately calibrated on any one range of the  $\mu$ STRAIN/DIV switch, the accuracy of all other range steps is within 2% of the indicated strain sensitivity.

### Accessories

Information on accessories for use with this instrument is included at the rear of the mechanical parts list.

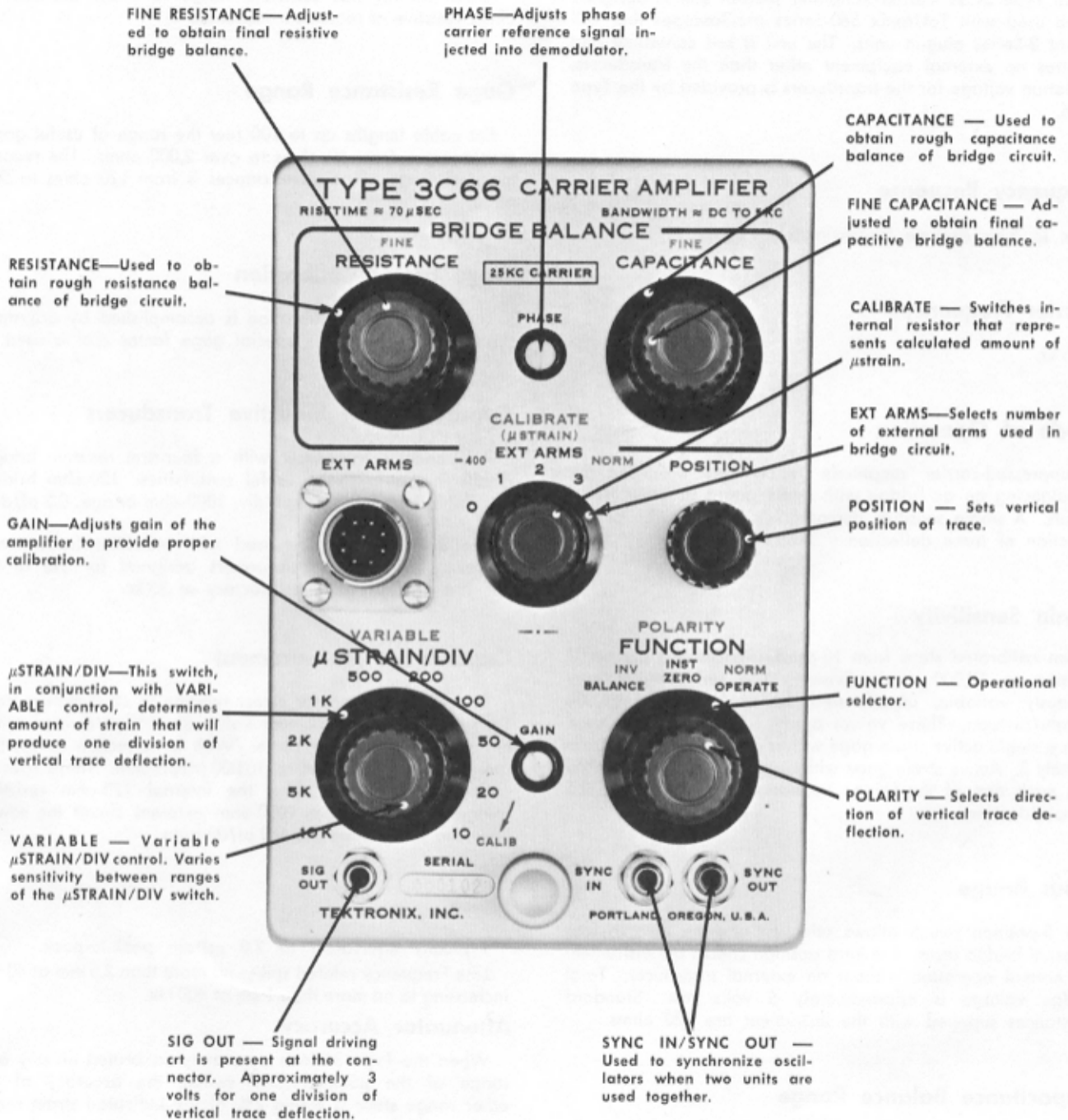

Fig. 2-1. Functions of Type 3C66 front-panel controls.

# SECTION 2

## OPERATING INSTRUCTIONS

### General Information

The Type 3C66 Carrier Amplifier plug-in unit can be used with any 560-Series oscilloscope that will accept 3-Series plug-in units.

This section of the manual describes the Type 3C66 operation. To get the most from the instrument, you should become familiar with the operation of each control.

Operation of the unit is described using resistance type strain gages; however, other types of transducers may be used (see Applications section). The Type 3C66 has a self-contained bridge circuit that self-checks the unit without external connections. The function of front-panel controls is shown in Fig. 2-1.

### Selecting the Strain Gages

To prepare the Type 3C66 for operation, first select the strain gages to be used.

When shipped, the Type 3C66 is calibrated for 120-ohm strain gages with gage factors of 2.00. If a strain gage of different resistance or gage factor is used, a short calibration procedure must be performed. See Fig. 2-2 for location of plug-in bridge and calibration resistors.

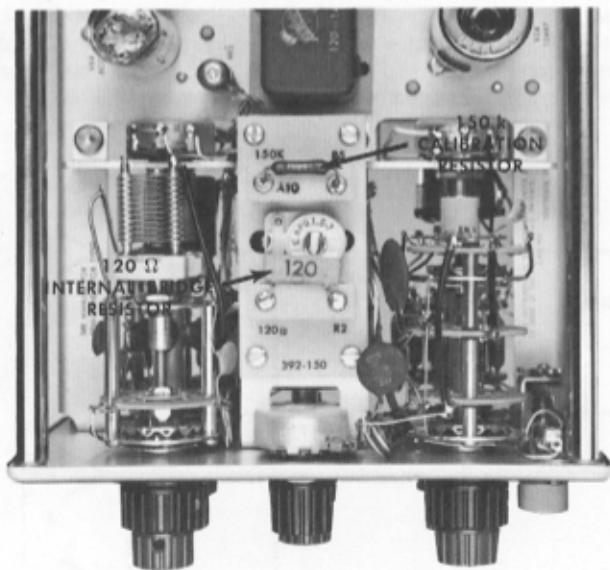

Fig. 2-2. Location of the Type 3C66 calibration and internal bridge resistors. Resistors may either be plugged in, as shown, or connected to the binding posts.

To calibrate the unit for a different strain-gage resistance, you may need to change a plug-in calibration resistor. The proper value for this resistor can be found from the information in this section under "Selecting a Special Calibration Resistor." The resistor can either be plugged into the unit or attached to convenient binding posts. The nominal value

of the internal bridge resistor must be the same as the resistance of the strain gage used in the external arm, or another strain gage may be attached to the binding posts to serve as the internal bridge resistance. The unit can then be balanced and calibrated as described later in this section.

The second consideration in choosing a strain gage is the gage factor. Best operation is obtained with a gage factor of 2.00. When gage factors other than 2.00 are used, you must reset the front-panel GAIN control to compensate for the change. This is described under "Setting the Gain Control" later in this section. The range of the GAIN control allows gage factors from approximately 1.5 to 6 to be used without changing the range steps of the  $\mu$ STRAIN/DIV switch. Strain gages with gage factors outside this range can be used but the panel markings on the  $\mu$ STRAIN/DIV switch must be changed.

When extremely high sensitivity is needed, use a strain gage with a high gage factor, or use more than one active gage. Remember that temperature instability accompanies a high gage factor. Because the Type 3C66 is capable of high amplification, you seldom need to use gage factors greater than 2.

### Selecting the Number of External Arms

Electrical connections for any number of external bridge arms up to four are shown in Fig. 2-3. These circuits are considered "normal" in the sense that almost all the resistive applications for the Type 3C66 will use one of the four lead connections shown. In addition, the standard cable provided can be used without modification and the panel markings associated with the EXT ARMS switch are directly applicable.

Actual selection of the number of external arms by the Type 3C66 is made with the EXT ARMS switch. In the 0 position of this switch, the internal bridge circuit of the Type 3C66 is used. This position can be used for checks of instrument operation without requiring external connections if the 120-ohm internal bridge resistor is inserted in the terminals provided.

Satisfactory performance is possible over a range of bridge arm resistances from 50 to 2000 ohms. The following information assumes operation within these limits.

**One External Arm.** The simplest type of strain-gage application uses only one external bridge arm. In short-lead applications, it is often possible to use the "One External Arm" connection shown in Fig. 2-3. This connection usually provides adequate stability at room temperature. Whenever a single external-arm connection is used, a suitable bridge-arm resistor must be connected to the terminals inside the unit.

Where long leads are required, the added cable resistance and inductance in series with the external arm introduces bridge unbalance. Fig. 2-4 shows a special cable connection that corrects for a large part of this unbalance. The lead from the strain gage to pin F is in series with an internal arm of the bridge and balances the lead drop from the

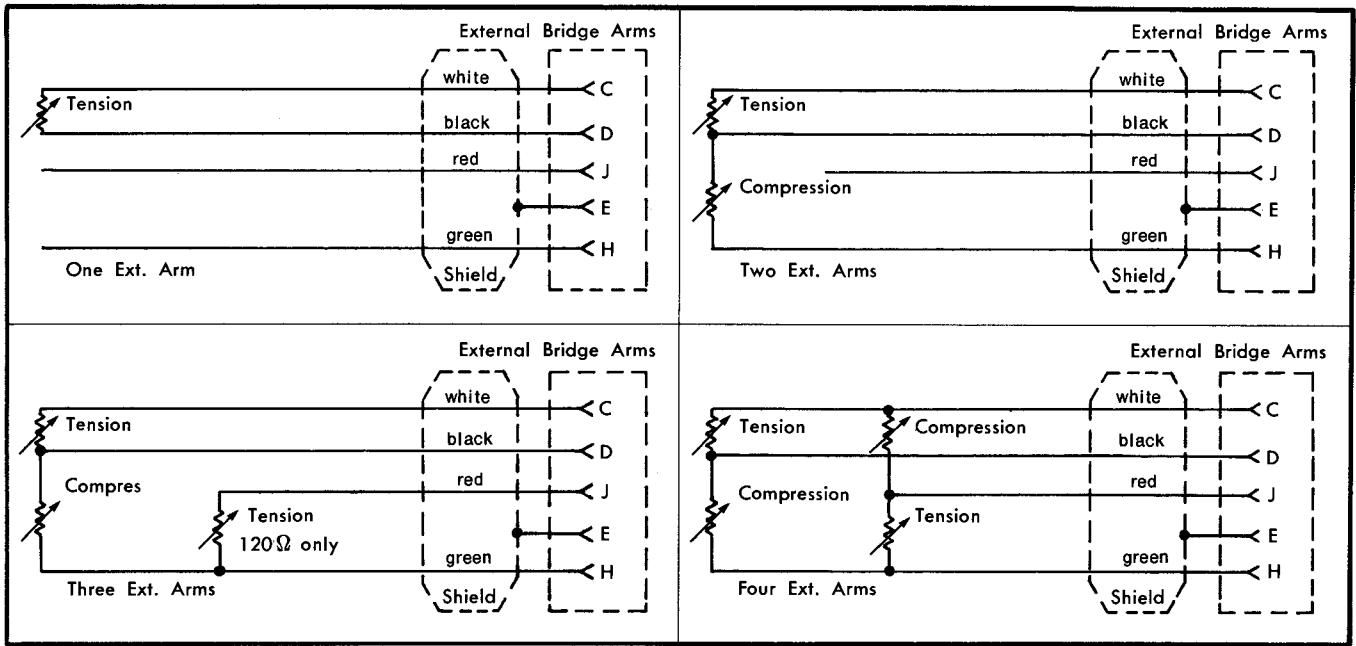

Fig. 2-3. Normal circuit connections for resistive transducers using four-conductor microphone cable. Transducers mounted as shown will produce maximum upward displacement of the oscilloscope trace when the POLARITY switch is at NORM.

strain gage to pin C. The lead from pin H provides capacitive balance. Note that the lead connection sequence to the connector must be modified from the standard cable (see Fig. 2-6) for this special hookup.

**Two or Four External Arms.** Two- and four-arm connections are much the same. Lead and circuit symmetry allow the bridge to be balanced over a wide range of cable lengths and bridge impedances. These connections should be used whenever possible. The two-arm connection re-

quires the impedances of the two external arms to be nearly equal. When four external arms are used, the resistances are not critical as long as the nominal values bring the bridge within the range of the balance controls. For example, the resistances used in arms 1 and 2 can be the same or different from the resistance in arms 3 and 4. Using more than one external arm provides greater sensitivity when the strain gages can be mounted to aid each other. Maximum sensitivity can be obtained with four active external arms.

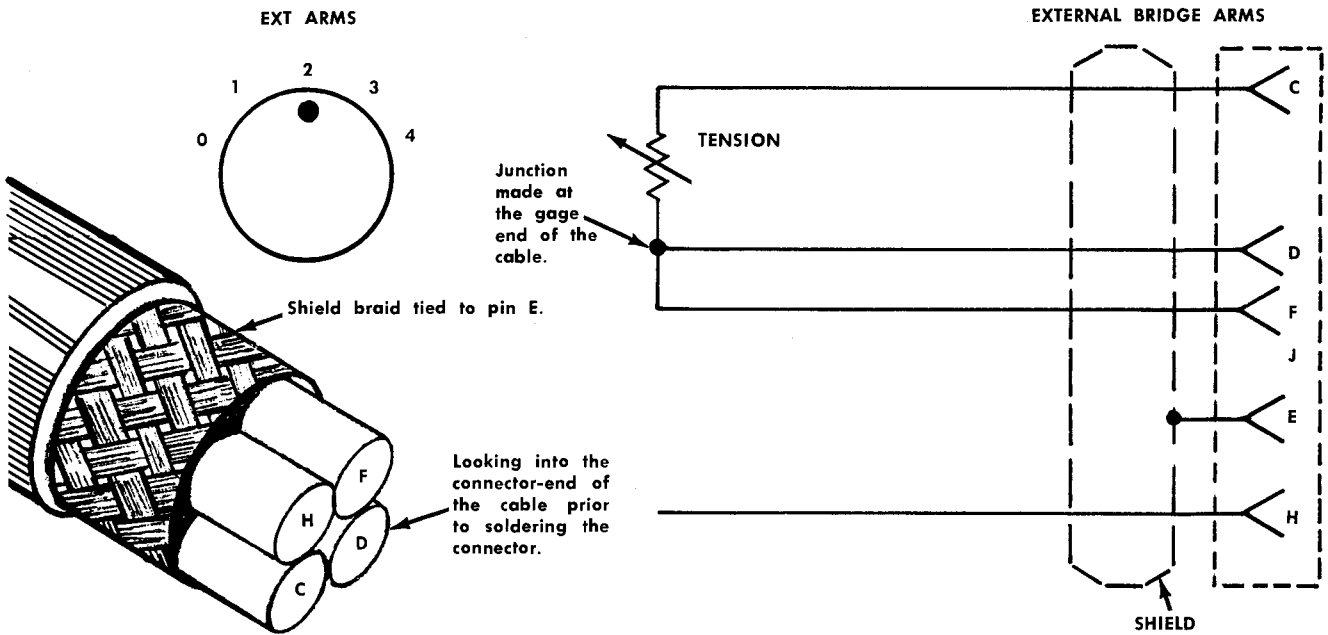

Fig. 2-4. Circuit connections for lead compensation (temperature and length). With the POLARITY switch at NORM, tensile strains in the gage will produce an upward deflection of the trace. The EXT ARMS switch must be set as shown to obtain the proper lead compensation.



An additional reason for using two or four external arms is stability. Environmental changes (primarily temperature) that produce changes in resistance of one strain gage, produce about the same change in the other strain gage. Bridge unbalance due to these changes is thereby cancelled. If two or four external arms are used, all arms need not be active. Strain gages can be connected into one or more of the external arms without being mechanically attached to the device under test. If dummy strain gages are used, they should be connected at the strain-gage end of the interconnecting cable and placed in approximately the same environmental conditions as the active arms. This provides the same stability as though all external arms were active and allows the bridge to be balanced in long-lead applications. Dummy gages should be cemented to unstressed material of the same composition as the material to which the active gages are cemented. The use of unbonded gages is not recommended.

When any number of external arms except four are used, switch contacts are in series with at least one of the bridge arms. These switch contacts are a source of possible unbalance due to contact resistance. In the most sensitive range of the Type 3C66, a resistance change in one arm of approximately 0.0025 ohm will produce one division of deflection on the associated oscilloscope (120-ohm gages assumed).

Thus, any slight change in contact resistance could produce considerable deflection of the trace. When four external arms are used, the switch contacts are out of the circuit and the problem is eliminated.

**Special Two External-Arm Connection.** Occasionally, a connection is needed for two active gages subjected to the same kind of stress. See "Force Measurement With Longitudinally Stressed Members" in Section 3. Fig. 2-5 shows this connection without the use of external dummy

gages. Where the temperature environment allows such operation, (resistance drifts due to temperature changes in the two gages are additive) this circuit can be used to good advantage. It is limited to short-lead applications, since lead impedances tend to unbalance the bridge. The use of this circuit requires modification of the lead connections at the connector and a special setting of the EXT ARMS switch.

**Three External Arms.** Three external arms are seldom used in strain and transducer measurements. This switch position is useful when using the special two external-arm connection mentioned previously. When three external arms are used, any value of strain-gage resistance can be used in arms 1 and 2 if the impedance in the two arms is approximately the same. The strain gage used in arm 3 must be 120 ohms, unless the arm 4 internal resistor is unsoldered and replaced by a value equal to the resistance of the arm 3 strain gage.

### Selecting the Interconnecting Cable

Many types of shielded cable can be used with the Type 3C66. The ability of the Type 3C66 to reject interfering signals simplifies the grounding and shielding problems associated with high-gain amplifiers. In general, unshielded cabling is not recommended although many short connections will work satisfactorily if the unshielded leads are laced together carefully to avoid lead crossovers.

Four-conductor shielded cable is a general purpose cable that can be used for all measurements regardless of the external circuit. Connections to the input bridge circuit are made in such a way that the interlead capacitances tend to maintain a balanced bridge regardless of the length of the interconnecting cable. Thus, the capacitance balance controls need only correct for minor irregularities.

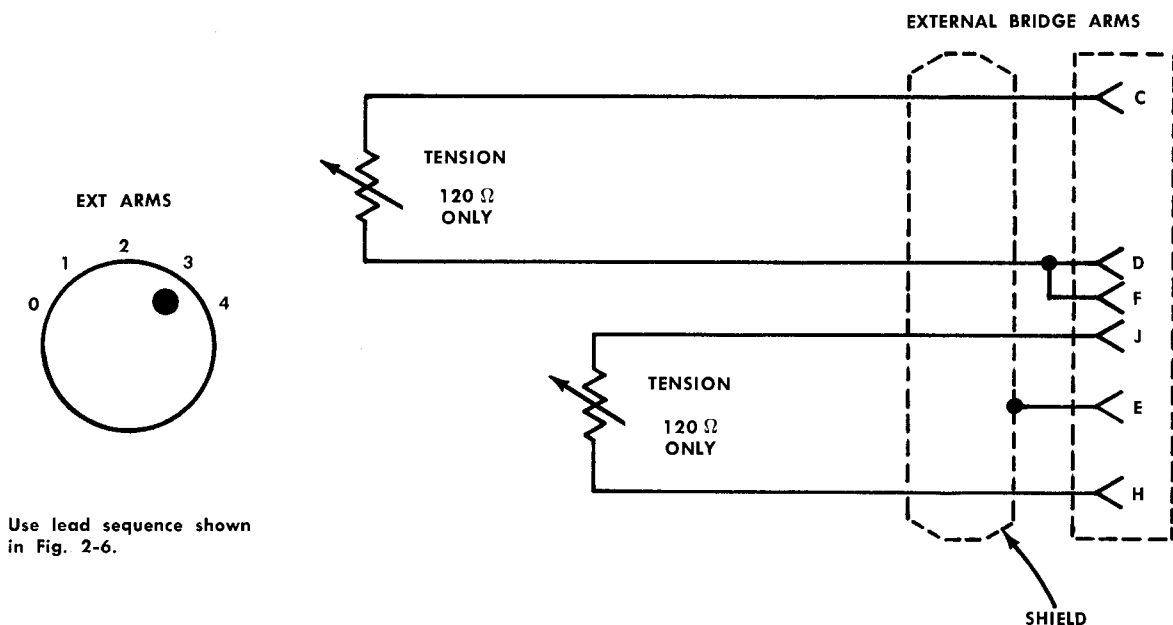

Fig. 2-5. Circuit connections for strain gages connected in opposite arms of the bridge. With the POLARITY switch at NORM, tensile strains in the gages will produce an upward deflection of the trace.

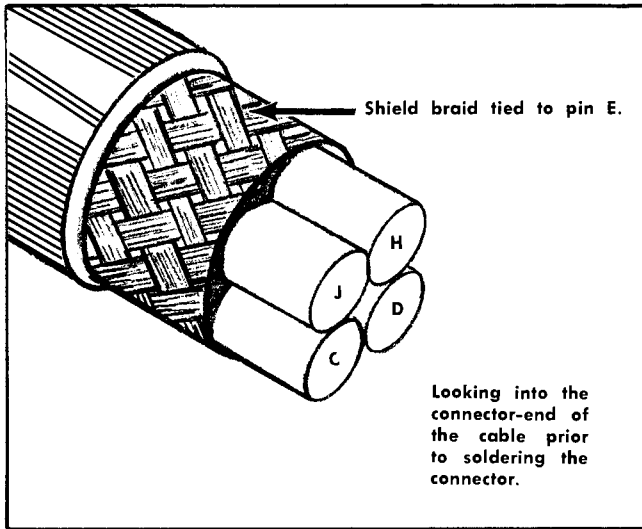

Fig. 2-6. Typical four-conductor shielded microphone cable. Letters indicate corresponding connector pin.

Fig. 2-6 shows the arrangement of four conductors inside the shield of a typical cable. The capacitance between adjacent pairs of leads (i.e., C and D) is much greater than the capacitance between diagonal pairs (i.e., D and J). Make solder connections as follows:

1. Solder the shield lead to pin E of the connector.
2. Looking at the end of the cable, select a ground lead and solder it to pin D.
3. Avoid lead crossover and connect the remainder of the leads to pins C, J, and H. Fig. 2-3 shows the electrical connections for any number of external arms.

**Three-Conductor Shielded Microphone Cable.** For applications that require only two external bridge arms, three-conductor shielded cable should be used. This cable is balanced capacitively so that no special precautions are required in making the lead connections. Except for the connection to pin J, three-conductor cable uses the same circuit as shown for four-conductor cable (where applicable).

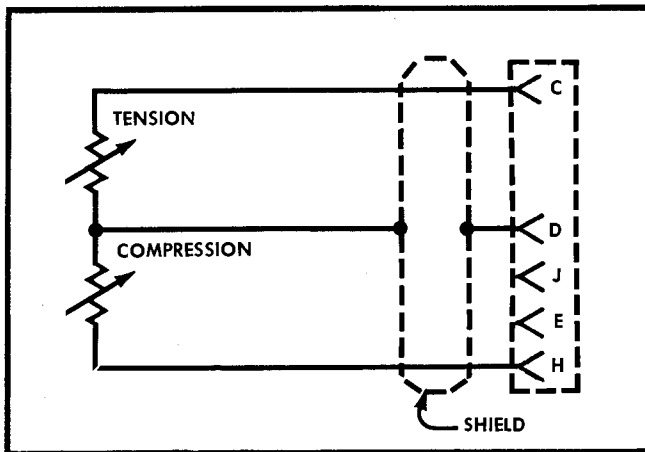

Fig. 2-7. Electrical connections for resistive transducers using two-conductor shielded cable.

**Two-Conductor Shielded Microphone Cable.** Fig. 2-7 shows circuit connections using two external resistance bridge arms and a two-conductor shielded cable. The shield braid is used as one of the signal leads. If the braid is grounded at the test side, differences of potential between the test-side ground and the oscilloscope ground can appear at the Type 3C66 input. Except in extreme cases, this connection does not introduce an objectionable amount of interference or hum. Generally, three-conductor cable is preferred in this application.

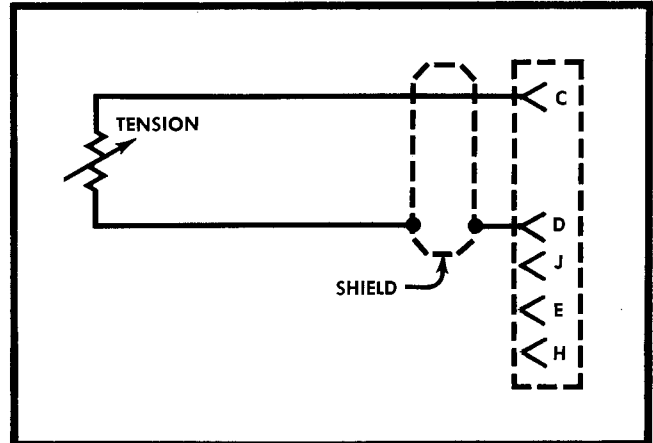

Fig. 2-8. Electrical connections for one external arm using single-conductor shielded (coaxial) cable.

**Single-Conductor Shielded Microphone or Coaxial Cable.** Connections for this type of installation are shown in Fig. 2-8. The capacitance of a single-conductor cable varies from 10 pf/ft to 100 pf/ft depending upon the design. Since all of this cable capacitance is in parallel with one arm of the input bridge, the Type 3C66 CAPACITANCE controls must compensate for this capacitance. If an appreciable length of cable is used, a capacitor with a value approximately equal to the total cable capacitance (within 250 pf) must be added in parallel with the internal plug-in bridge-arm resistor. This brings the circuit within the range of the CAPACITANCE controls. The binding posts should be used for addition of this capacitor. Single-conductor cable should not be used when multiple-conductor cable is available.

### Connecting the Cable to the Amphenol Connector

1. Remove the protective insulating jacket from the end of the cable. The insulating jacket should be stripped back about 2 inches.
2. Disassemble the connector and place all the parts in their proper order on the cable except the connector body and connector insert.
3. Slide the shield braid down over the wires.
4. Select the ground lead (pin D of the connector). Use a pointed (but not sharp) tool and spread the braid wires apart on the opposite side from the ground lead at a point

close to the end of the insulating jacket. Reach behind one of the leads with your pointed tool and gradually work the lead out through the opening. Repeat for the other leads and packing string until the braid is empty. Stretch the braid out to form a pigtail.

5. Loop a piece of tinned bare wire over the braid approximately  $\frac{1}{8}$  inch from the point where the leads are brought out through the shield. Crimp the wire lightly and then solder with a freshly tinned iron and rosin-core solder. Heat the braid *rapidly* and *briefly* during the soldering operation to avoid melting the lead-wire insulation.

6. Cut off the excess lead including the bare wire. Strip each lead back  $\frac{1}{4}$  inch (be careful not to cut the stranded wires).

7. Cut  $\frac{1}{2}$ -inch lengths of spaghetti tubing (No. 12 spaghetti recommended) to go over the ends of the leads. Slip the tubing back over the leads as far as it will go. A small amount of wire insulation should protrude so that the leads can be identified. No spaghetti is required on the braid extension lead.

8. Clamp the molded connector insert lightly in a bench vise or other support with the solderpots up. Work from the bottom upwards in soldering the leads.

9. When all the leads are soldered, inspect each joint carefully for rosin or frosty solder joints.

10. Push the spaghetti up over the solder pots until each piece is flush with the molded insert. Secure the spaghetti in position with plastic insulating tape.

11. Assemble the connector with the insert pushed all the way in to the key. Do not tighten excessively.

12. Use an ohmmeter and measure the resistance of each lead to ground.

13. Cable with four or more conductors should be checked to see that leads are capacitively balanced before connecting to a transducer. Attach the cable connector to the Type 3C66 input and balance the bridge with the EXT ARMS switch in the 0 position. (The 120-ohm internal bridge resistor must be in place.) A miswired cable of appreciable length will not allow bridge balance.

## Attaching Strain Gages

Techniques for attaching strain gages to a device under test are beyond the scope of this manual. However, a number of excellent texts are available which present this information. Generally, installation information is provided with strain gages.

Strain gages must be soldered to the proper leads of the interconnecting cable. It is important that good solder joints be made to prevent erratic operation.

## Balancing the Input Bridge Circuit

Insert the Type 3C66 into the proper plug-in compartment of the oscilloscope and turn on the power. Connect the strain gages to the Type 3C66 and allow several minutes for warmup. Adjust the oscilloscope time-base plug-in unit for automatic internal triggering. Set the Type 3C66 POLARITY switch to NORM and the FUNCTION switch to INST ZERO.

Use the POSITION control to center the trace on the crt. Then set the FUNCTION switch to BALANCE and the  $\mu$ STRAIN/DIV control to 2K. With the FINE RESISTANCE and FINE CAPACITANCE controls set at midrange, turn first the RESISTANCE then the CAPACITANCE switches for minimum vertical deflection. Adjust the FINE RESISTANCE and FINE CAPACITANCE controls for minimum vertical deflection. Set the  $\mu$ STRAIN/DIV switch to 100 and readjust the BRIDGE BALANCE controls for minimum vertical deflection. Set the  $\mu$ STRAIN/DIV switch to 10 and again adjust the BRIDGE BALANCE controls for minimum deflection. The bridge will now be in proper balance. Set the FUNCTION switch to OPERATE and the  $\mu$ STRAIN/DIV switch to the desired strain sensitivity.

With the strain gages in an unstressed condition, the bridge can be checked for proper balance by placing the FUNCTION switch in the BALANCE position. If the bridge is correctly balanced, no signal should appear on the crt.

## Adjusting the PHASE Control

The PHASE control allows the use of either resistive or reactive transducers. When the control is adjusted properly, the Type 3C66 has maximum overall sensitivity. The control must be readjusted each time a different transducer circuit is used. The control should also be checked periodically when the Type 3C66 is used with the same transducer circuit. The control has sufficient range for either resistive or reactive transducers.

With the strain gages connected and the bridge balanced (CALIBRATE switch in the NORM position), set the  $\mu$ STRAIN/DIV switch to 100. Set the POLARITY switch to NORM and position the oscilloscope trace to the top of the graticule. Set the FUNCTION switch to OPERATE and the CALIBRATE switch to -400. Adjust the PHASE control for maximum downward deflection of the trace. The BRIDGE BALANCE controls and the PHASE control interact slightly. Recheck the balance and readjust the phase, if necessary.

## Correcting for Lead Impedance

Corrections for lead impedance are not required in most short-lead applications. When the leads are long and/or the strain-gage resistance is very low, the lead impedance correction may be needed. For carrier amplification systems the effects of the lead resistance, inductance, and capacitance are fairly complex and it is not practical to calculate the correction coefficient. However, the correction may be determined as follows:

1. First, calibrate the Type 3C66 in the normal manner with the lead length and gage resistance that you expect to use.

2. Remove the calibration resistor from the Type 3C66 and connect it directly across the strain gage itself. Avoid hand-capacitance effects during this operation.

3. Determine the ratio of the two deflections obtained in steps 1 and 2. This is the required correction coefficient.

Once the correction is found for a particular cable connection, cable length, cable type, and strain-gage resistance, it need not be determined again. The cable impedance changes the effective gage factor. Therefore, multiply the

Operating Instructions — Type 3C66

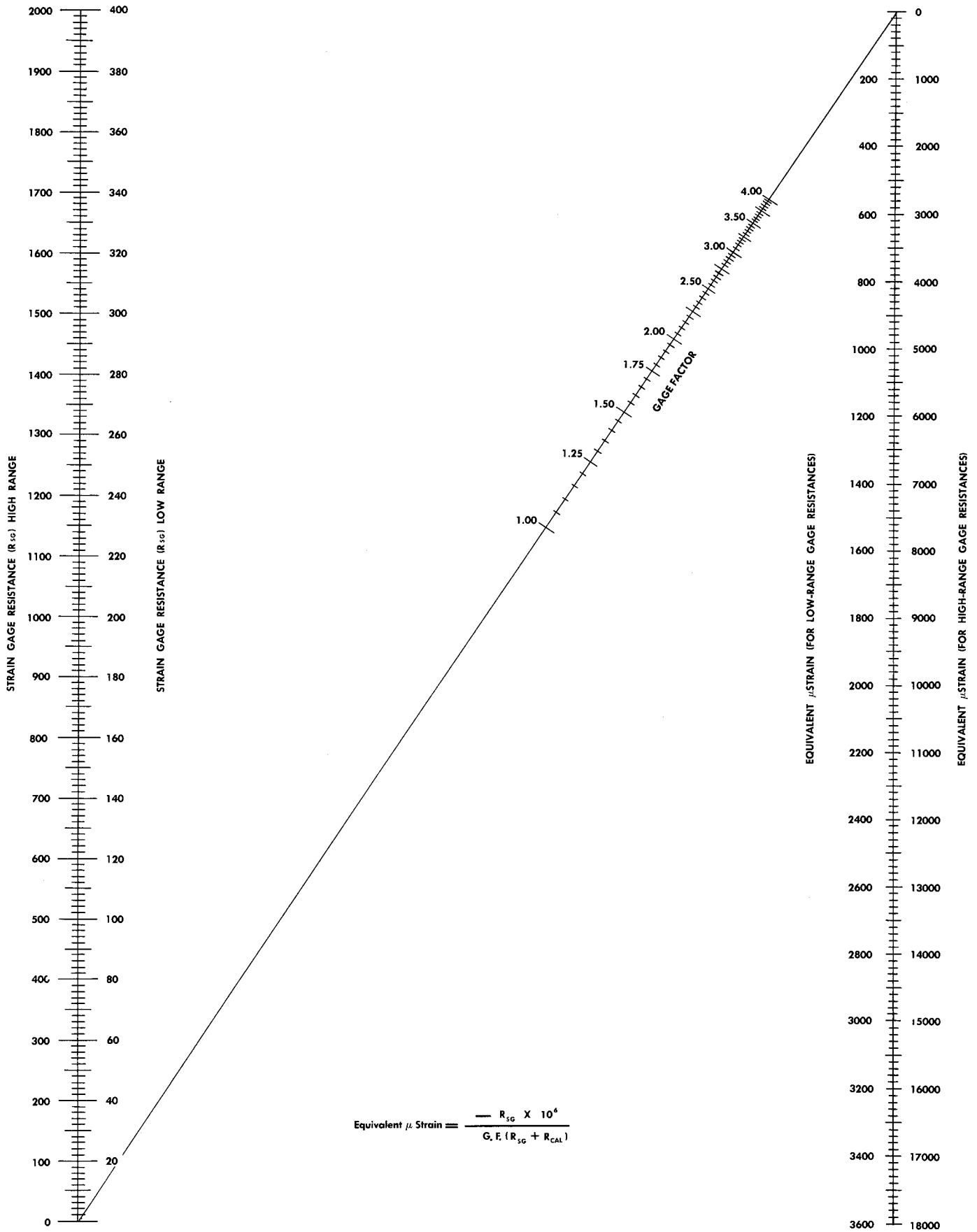

Fig. 2-9. Nomograph for the 150-k calibration resistor. This nomograph can be used to find the equivalent μstrain produced by the 150-k calibration resistor when the unit is used with transducers with various resistances and gage factors.

gage factor by the experimental coefficient determined. This new gage factor can be used in setting the GAIN control.

### Calibration Using the Standard Resistor

In most resistive applications, the Type 3C66 can be calibrated with the standard 150 k calibration resistor supplied with the unit. This resistor is stable and accurate with good electrical properties at 25 kc. Operating the CALIBRATE switch on the Type 3C66 front panel connects the calibration resistor in parallel with the bridge arm between pins C and D of the EXT ARMS connector. This reduces the resistance of the bridge arm, and is equivalent to subjecting the strain gage to a compressive (negative) strain.

With a 120-ohm strain gage (gage factor of 2.00), the calibration resistor is equivalent to  $-400 \mu\text{strain}$  as marked on the front panel. The equivalent strain simulated with other gage resistances and gage factors may be found from the nomograph in Fig. 2-9. For values lying outside the range of the nomograph, and for greater precision, the following equation may be used:

$$\text{Equivalent } \mu\text{strain} = - \frac{R_{SG} \times 10^6}{(G.F.)(R_{SG} + R_{CAL})} \quad (1)$$

where:

G.F. = Gage Factor of strain gage.

$R_{SG}$  = Strain-gage resistance.

$R_{CAL}$  = Calibration resistor value.

For example, using a 200-ohm strain gage with gage factor of 1.75 and the 150 k calibration resistor, the equivalent  $\mu\text{strain}$  will be  $-761$ . This value is used in setting the plug-in sensitivity as explained under "Setting the GAIN Control", later in this section.

### Selecting a Special Calibration Resistor

The actual calibration procedure is simplified by using a special calibration resistor to simulate a particular strain level. The value of the calibration resistor may be determined from the formula:

$$R_{CAL} = - \frac{R_{SG}}{(G.F.)(\text{Strain})} - R_{SG} \quad (2)$$

For example, to determine the proper calibration resistance for a 200-ohm gage with a gage factor of 1.75 at a strain level of  $-2,000 \mu\text{strain}$ :

$$\begin{aligned} R_{CAL} &= - \frac{200}{(1.75)(-2000 \times 10^{-6})} - 200 \\ &= 57,142 - 200 \\ &= 56,942 \text{ ohms.} \end{aligned}$$

Use a precision deposited-film resistor. Wirewound resistors are not satisfactory because of stray inductance and capacitance effects at 25 kc. The required accuracy and resistance value can be obtained with series or parallel combinations of two resistors. Precision 1% metalfilm resistors with nominal values corresponding to the 1% military specification list are stocked by commercial suppliers. These resistors may also be purchased through your local Tektronix Field Office.

The calibration resistor supplied with the unit plugs into special holders as shown in Fig. 2-2. This resistor can be removed by unplugging it from the holder and the new calibration resistor can be attached to the binding posts. You can purchase blank plug-in board assemblies from Tektronix, Inc. (part no. 392-124) on which to conveniently interchange special calibration resistors.

#### NOTE

In equations (1) and (2), it is assumed that the transducer leads are short and the lead impedance is negligible. For a discussion of the effects of lead impedance on effective gage factor, refer to "Correcting for Lead Impedance" earlier in this section.

### Polarity Switch

Normally, bridge circuit connections are made so that the trace will deflect upward for tensile strains. The POLARITY switch reverses deflection polarity without reconnecting the bridge elements. There may be a slight gain change when the switch is operated. For best accuracy, set this switch before setting the front-panel GAIN control.

### Setting the GAIN Control

The GAIN control (front-panel screwdriver adjustment) is adjusted to make the  $\mu\text{STRAIN}/\text{DIV}$  switch direct reading for strain measurements. Equation (3) relates the number of major graticule divisions to a particular calibration strain and  $\mu\text{STRAIN}/\text{DIV}$  switch setting.

$$\text{Division of Trace Deflection} = \frac{\text{Calibration Strain}}{\mu\text{STRAIN}/\text{DIV Switch Setting}} \quad (3)$$

In equation (1) under "Calibration Using the Standard Resistor", the strain simulated by the 150 k calibration resistor for specific nonstandard conditions is  $-761 \mu\text{strain}$ . Using this figure, calibrate the Type 3C66 at 100  $\mu\text{strain}/\text{div}$  sensitivity.

From equation (3):

$$\text{Division of Trace Deflection} = \frac{-761}{100} = -7.61 \text{ divisions}$$

To perform the actual calibration:

1. Set the  $\mu\text{STRAIN}/\text{DIV}$  switch to 100.
2. Position the trace to the top of the crt.
3. Operate the CALIBRATE switch. The trace should deflect downward.
4. Adjust the GAIN control for a deflection of 7.61 major graticule divisions. Return the CALIBRATE switch to NORM.

The  $\mu\text{STRAIN}/\text{DIV}$  switch is now calibrated for direct reading at all settings.

With the internal 120-ohm bridge resistor and the calibration resistor supplied (EXT ARMS switch set to 0), the equivalent strain is  $-400$  as marked on the front panel. This assumes a gage factor of 2 and the deflection should be 4 major divisions with the  $\mu\text{STRAIN}/\text{DIV}$  switch at 100.

## Operating Instructions — Type 3C66

This procedure checks that the unit is operating properly with no external strain gages or transducers connected.

The range of the GAIN control will accommodate most gage factors and resistances used in standard foil- and wire-type strain gages.

### Synchronizing Oscillators

The SYNC IN and SYNC OUT connectors are used to synchronize the oscillator frequencies of two or more units. This prevents beat notes from appearing on the crt. A synchronizing cable (Tektronix part no. 012-063) is supplied with each unit for this connection. Connect from the SYNC OUT connector on one unit to the SYNC IN connector on the other unit. Additional units may be synchronized by continuing this sequence.

If the oscillators do not synchronize properly, the cable should be removed and the oscillator frequencies adjusted

to exactly 25 kc as outlined in the Calibration section of this manual. Then replace the cable.

### Signal Output Connector

The SIG OUT connector allows the output of the Type 3C66 to be fed into an external amplifying or indicating device. The signal level is not calibrated exactly but is about 3 volts/major graticule division.

### Other Transducer Types

For simplicity, this section of the manual has been restricted to examples related to the strain-gage field. However, the Type 3C66 can also be used with other resistive, capacitive, and inductive transducers. Information regarding the calibration and installation of other types of transducers is included in the Application section of this manual.

# SECTION 3

## APPLICATIONS

### Introduction

In general, any mechanical quantity can be measured with the Type 3C66 if the quantity can be converted to a change in resistance, capacitance, or inductance by a transducer. This often involves only the connection of a commercially available transducer to the device under test. For special applications, it may be necessary to build a simple transducer.

### Strain and Gage Factor Definitions

Two common terms used with strain-type instruments are easily defined but often misunderstood.

Suppose a straight piece of metallic wire as a "free length"  $L$ . Free length means the length of the wire when it is lying on a flat surface without being subjected to external forces. If the wire is pulled by a force  $F$  as shown in Fig. 3-1, the wire will lengthen slightly. This is shown in the figure by the dotted length  $\Delta L$ . For most structural materials, the amount of stretch is too small to be seen by the human eye but is easily measured by sensitive equipment. The ratio of  $\Delta L$  to the unstressed length  $L$  (a measure of the deformation of the molecular bonds in the material) is called the "strain". Since  $\Delta L$  and  $L$  are both length units, their ratio is a pure number having no units. Strain value is numerically the same whether it is expressed in the English system or the metric system.

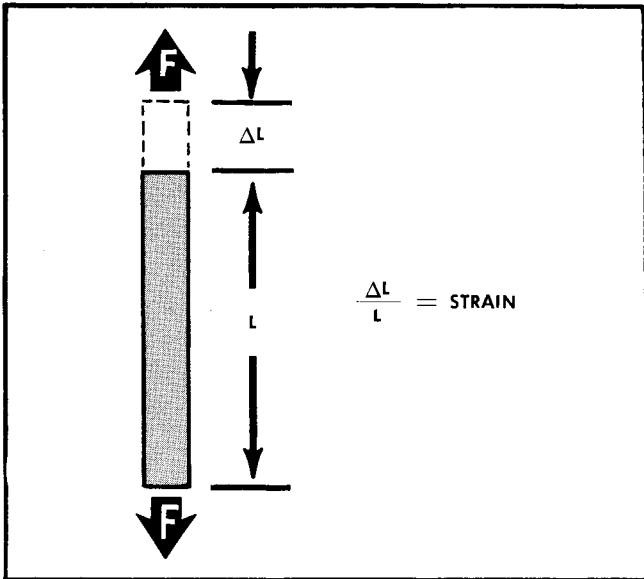

Fig. 3-1. Basic factors involved in definition of strain.

The preceding example used a length of metallic wire; however, the basic strain definition applies to all solid materials and physical shapes. In many structures subject to external forces, the strain is not the same everywhere. A

measurement refers to the strain at a particular point in the material or to the average strain over a specified interval. Strain measurements using strain gages measure the average strain over the length of the gage wires.

The electrical resistance of a piece of wire is determined by the equation:

$$\text{Resistance} = \frac{(\text{resistivity of the material})(\text{length})}{(\text{cross-sectional area})}$$

For the wire stretched in Fig. 3-1, the length increased and the cross-sectional area decreased with the application of the force  $F$ . From the equation for resistance, this causes the resistance to increase. This is how resistive strain gages convert mechanical changes to electrical signals. The resistance of the wire always changes with strain but may either increase or decrease depending upon the properties of the material. Most conductive materials subject to stretching or tensile forces increase in resistance.

Changes in resistance are easily converted to voltage variations which can be displayed on an oscilloscope. To get quantitative data we need to know how the strain changes are related to the resistance changes. Over a wide range, the change in resistance is proportional to the strain.

Let  $\Delta R$  be the change in wire resistance corresponding to a change in length  $\Delta L$ . Then:

$$\frac{\Delta R}{R} = (\text{G.F.}) \frac{\Delta L}{L} = (\text{gage factor})(\text{strain}).$$

From this equation, the gage factor (G.F.) is a proportional factor between the strain and the decimal change in resistance. The gage factor must be known to make quantitative strain measurements with an oscilloscope.

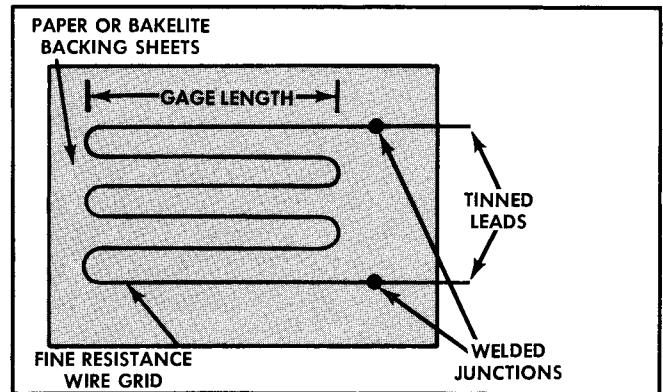

Fig. 3-2. Construction details of a resistance-wire strain gage.

An example of a strain gage is shown in Fig. 3-2. A length of fine resistance wire is doubled back and forth to form a resistive grid. Tinned leads are welded to the resistance wire for soldering. The grid is then cemented between

## Applications — Type 3C66

two layers of paper or similar material. This sandwich can be cemented to the surface of a device under test. In cementing the gage, the longitudinal axis of the wires is placed along the direction of strain measurement. As the material stretches and compresses, the gage wire is stretched and compressed in direct proportion.

Strain gages are manufactured in large quantities under controlled conditions so that the gage factor does not vary appreciably from gage to gage. The manufacturer determines the average value for the gage factor as well as the total deviations from the average . . . usually less than 2%. This information is supplied with the gage and is used in calibrating the Type 3C66.

### Temperature Compensation

Strain gages are usually made from materials with low temperature coefficients of resistance. Consequently, their resistance is only slightly affected by changes in temperature. Though these resistance changes are small, they may be appreciable in comparison to the resistance changes due to small strains being measured. Zero-drift errors due to temperature also occur. In addition to the temperature-induced resistance changes within the gage itself, there is a change in the strain-gage resistance due to the difference in the temperature coefficient of expansion between the strain-gage material and the structural material to which it is cemented.

One of the simpler methods for reducing temperature effects is to use two gages mounted to the structure and arranged electrically so that they are in adjacent arms of the Type 3C66 bridge.

A simple application is shown in Fig. 3-3. The gages are mounted on opposite sides of a beam subject to a bending force. Under these conditions, one strain gage will be subject to tensile strain while the other experiences compressive strain. Since both gages are affected by temperature in the same way, the bridge remains balanced for temperature variations but the gages will provide twice the sensitivity of one gage for beam deflections.

Self-compensating bridge circuits are convenient in transducer applications. However, in most strain measurements

you cannot find two gage locations having equal and opposite strains. It may be necessary to use a dummy gage cemented to a metal plate that sees nearly the same temperature environment but is unstressed. Mount the dummy gage on the same type material as the active gage for best results.

Another temperature compensation method uses special strain gages manufactured for use on specified materials. By designing these gages to have the same thermal expansion as the material for which they are compensated, the gage manufacturer reduces the temperature errors. Gages of this type are customarily used only when the temperature variations are a part of the test. With ordinary gages, temperature drift due to changes in temperature is usually small unless the test is of long duration and the Type 3C66 is operated at high sensitivity.

### Force Measurement with Longitudinally Stressed Members

Longitudinal force measurements are one of the simplest transducer applications of the Type 3C66. The following paragraphs describe the measurement of strain, stress, and force in a compression member. The methods apply to tension members as well.

Fig. 3-4 shows a short length of cold-rolled steel bar stock with a strain gage mounted near the center. The gage is cemented with its strain-sensing axis parallel to the longitudinal axis of the bar. When a uniformly distributed compression load  $F$  is applied to the ends of the bar, all parts of the bar are shortened in proportion to the force. Since strain is proportional to force, the deflection on the oscilloscope is also proportional to the force.

The stress in a structural material is the force per unit area at a particular point in the material. In this example, the stress is constant throughout the bar. In most materials the relationship between the stress and strain is nearly linear over a wide range. A typical curve for structural material is shown in Fig. 3-5. The slope of the curve is a measure (modulus) of the deformation of the material under load (elasticity). Hence, the name "modulus of elasticity" for the constant of proportionality between stress and strain. The modulus of elasticity  $E$  for all grades of carbon steel is

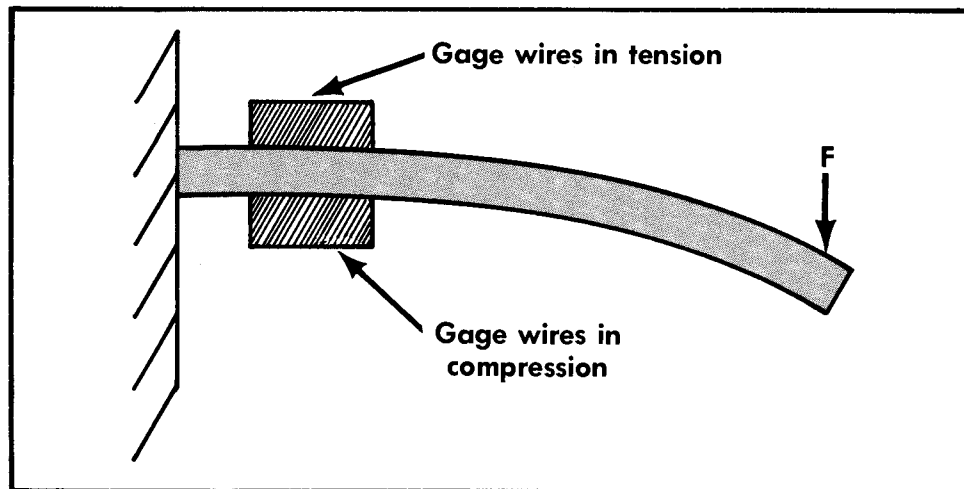

Fig. 3-3. Simple cantilever beam arranged to give self-compensation for temperature effects.



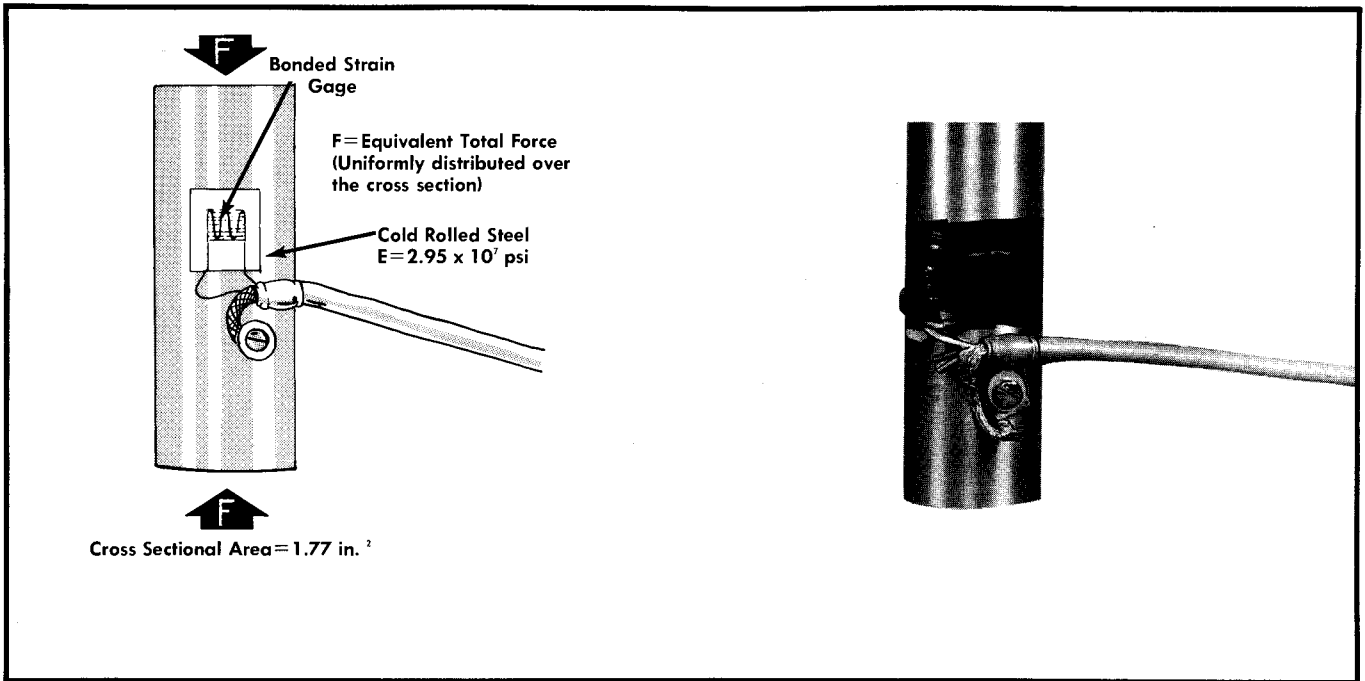

Fig. 3-4. Construction details of a simple force transducer.

very nearly  $2.95 \times 10^7$  psi. With the Type 3C66 calibrated for  $100 \mu\text{strain/div}$ , the following may be used to determine stress/div:

$$\begin{aligned} \text{Stress} &= (E) (\text{Strain}) \\ \text{Stress/Div} &= (E) (\text{Strain/div}) \\ &= (2.95 \times 10^7) (100 \times 10^{-6}) \\ &= 2950 \text{ psi/div} \end{aligned}$$

The oscilloscope calibration is now in terms of the material stress. To find the force/div, multiply the stress by the cross-sectional area of the bar. Stated mathematically:

$$\begin{aligned} \text{Force/Div} &= \left[ \frac{\text{Stress}}{\text{Div}} \right] \text{Area} \\ &= 2950 \frac{\text{lbs}}{(\text{in}^2) (\text{div})} (1.77 \text{ in}^2) \\ &= 5220 \text{ lbs/div.} \end{aligned}$$

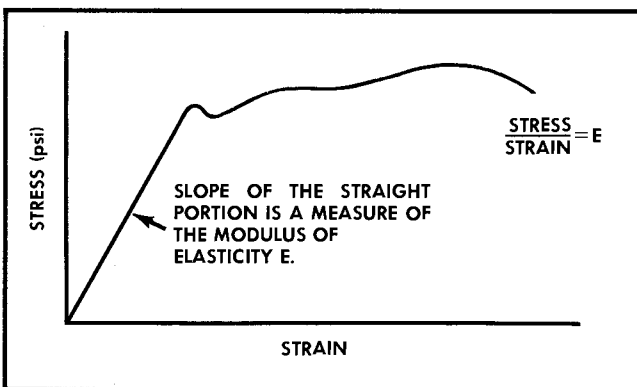

Fig. 3-5. Typical stress-strain diagram for structural steel.

If the Type 3C66 is used in a nonstrain application, you can make the calibration per division an integral multiple of the quantity being measured. This is done by adjusting the gain proportionately during the Type 3C66 calibration. In

the preceding example, 5000 lb/div would be a convenient value to use. This calibration can be made by applying a known force to the bar and adjusting the gain for the proper trace deflection. Or, you can select a calibration resistor that corresponds to the force value. The calibration resistor can then be used to set the gain. Starting with the desired force/div, calculate first the stress/div, then the strain/div for the bar. Then use the equations from the Operating Instructions section to find the value of the special calibration resistor.

The simple strain-gage installation shown in Fig. 3-4 is satisfactory where the strain is known to be evenly distributed over the member cross section. In a uniform member subject to bending stresses as well as longitudinal stresses, the longitudinal stresses can be measured independently by cementing two active strain gages on opposite sides of the member and connecting them in arms 2 and 4 of the bridge. This connection will give twice the sensitivity as well as measuring the average longitudinal strain. Circuit connections use the Type 3C66 in the 4 position of the EXT ARMS switch and completes the bridge circuit with two unstressed (dummy) arms. The most convenient way to do this is to mount two additional strain gages on a separate piece of metal to form the dummy arms. The dummy arms should be located in the same temperature environment as the active arms. The dummy arms can also be cemented to the force measuring bar at right angles to the longitudinal axis. Unfortunately, due to Poisson's effect, there exists a tensile strain along the transverse circumference of the bar. The magnitude of the tensile strain is approximately one-fourth as large as the longitudinal compressive strain. Unless Poisson's ratio for the metal is precisely known, the transverse strain cannot be calculated accurately. This presents no problem when equipment for calibrating the load cell against a standard is available. Some of the commercial force-measuring transducers use this method for locating

## Applications — Type 3C66

the dummy arms. The four-arm arrangement has excellent temperature stability. Use of four external arms also avoids inaccuracies due to switch or connector contact resistance, since connections in the bridge circuit are soldered directly.

### Resistive Transducers

Most of the commercial transducers used with the Type 3C66 operate on the resistance-variation principle.

The manufacturer supplies information regarding the shunt calibration resistor that corresponds to a specific transducer calibration. This allows you to use the calibration system built into the Type 3C66. In some cases, a correction for lead length may have to be applied. Best results are obtained when the transducer and Type 3C66 are calibrated with the proper lead length. The transducer can be calibrated experimentally by applying a known amount of the transduced quantity to the unit and observing the resulting trace deflection on the oscilloscope. By setting the GAIN control, the trace deflection can be made an integral number of graticule divisions. The calibration resistor can then be selected experimentally to produce the amount of trace deflection. When calibrating in this manner, the lead effect correction is automatically included.

An example of a resistive transducer application is a dynamic blood-pressure measurement. A commercial transducer is available for this purpose that uses a four-arm resistive bridge. The transducer has built-in venting valves to free trapped air from the pressure system. Connections are made from the transducer to the Type 3C66 through a special cable and connector. A resistor corresponding to a known pressure is then connected to the calibration-resistor binding posts within the Type 3C66. The pressure system is filled with fluid and the trapped air removed. The transducer and needle should be in approximately their normal position while the Type 3C66 bridge is being balanced. With the EXT ARMS switch in the 4 position, the bridge is balanced to establish the zero of atmospheric pressure calibration point. Next, the Type 3C66 gain is adjusted to give a specific deflection sensitivity in terms of mm of mercury/div. Finally, when the needle attached to the transducer is inserted into a blood vessel, the vertical deflection of the oscilloscope trace is directly proportional to the instantaneous blood pressure.

### Capacitive Transducers

Transducers that change capacitance with the transduced quantity are not used as often as resistive transducers. However, the simplicity of the capacitive transducer makes it useful in some applications. They are most often used in the measurement of mechanical displacements.

Two or more flat metallic plates are arranged so that their plane surfaces are parallel. If one plate is connected to ground through connector pin D and the other is connected to pin C, then the oscilloscope deflection is proportional to the area of the plate overlap if the areas are large enough to reduce edge effects. Two plates can be connected mechanically to two points in a machine where the displacement is to be measured. The plate connected to pin C must be insulated from ground. In some cases,

electrical interference (brush noise in a series motor for example) may require electrostatic shielding.

When the motion does not occur along a straight line, the transducer plates will have to be specially shaped and/or spaced to provide a linear relationship between the trace deflection and the motion.

Another mechanical arrangement can be in the form of coaxial-concentric cylinders. The amount of straight-line displacements can be measured even when the amount of travel is great. If the transducer capacitance corresponding to "zero" displacement is greater than 250 pf, a fixed capacitor must be added across R2 (use the binding posts for this purpose) to bring the bridge capacitance within the range of the CAPACITANCE balance control. Use a capacitor value within 250 pf of the transducer zero capacitance including the effect of any lead unbalance. A mica capacitor or other temperature insensitive capacitor should be used in this application.

To measure small displacements (a few thousandths of an inch or less), change the spacing between the plates of a capacitive transducer. One of the plates can be a machine surface and the other a test probe of small diameter.

Fig. 3-6 shows how the capacitance changes with spacing for a 1/4-inch diameter probe. Since the capacitance is a non-linear function of the spacing, a correction factor must be used.

Capacitive transducers can be calibrated by using a calibration capacitor connected within the Type 3C66. Or, use two static calibration points by moving the machine or device by hand and setting the Type 3C66 gain for a known displacement. Make one of the calibration points the end of the travel or zero point to reestablish a reference balance to check for thermal drift. The amount of capacitance change in transducer work is small enough so that the bridge unbalance will not affect linearity.

### Special Transducers

In some measurement problems commercial transducers are not available. It is often possible to design a transducer to meet these needs.

For example, Fig. 3-7 shows a transducer designed to measure water-wave action in hydraulic models. Two electrodes are inserted into a fluid (tap water in this example) and as the water rises and falls relative to the fixed transducer, the total resistance of the water between the electrodes changes. Even with relatively pure water the change in resistance for moderate depth changes (D) is enough to operate the Type 3C66. To avoid nonlinearity, bridge only a portion of the resistive arm with the water conduction path as shown in Fig. 3-7. Calibration is accomplished by moving the transducer a known amount relative to the water and setting the Type 3C66 gain.

If the water contains soluble impurities there will be no electrolytic deposition because the ac bridge excitation reverses the current flow each half cycle. If the electrodes are totally immersed, the device will measure changes in solution conductivity or temperature.

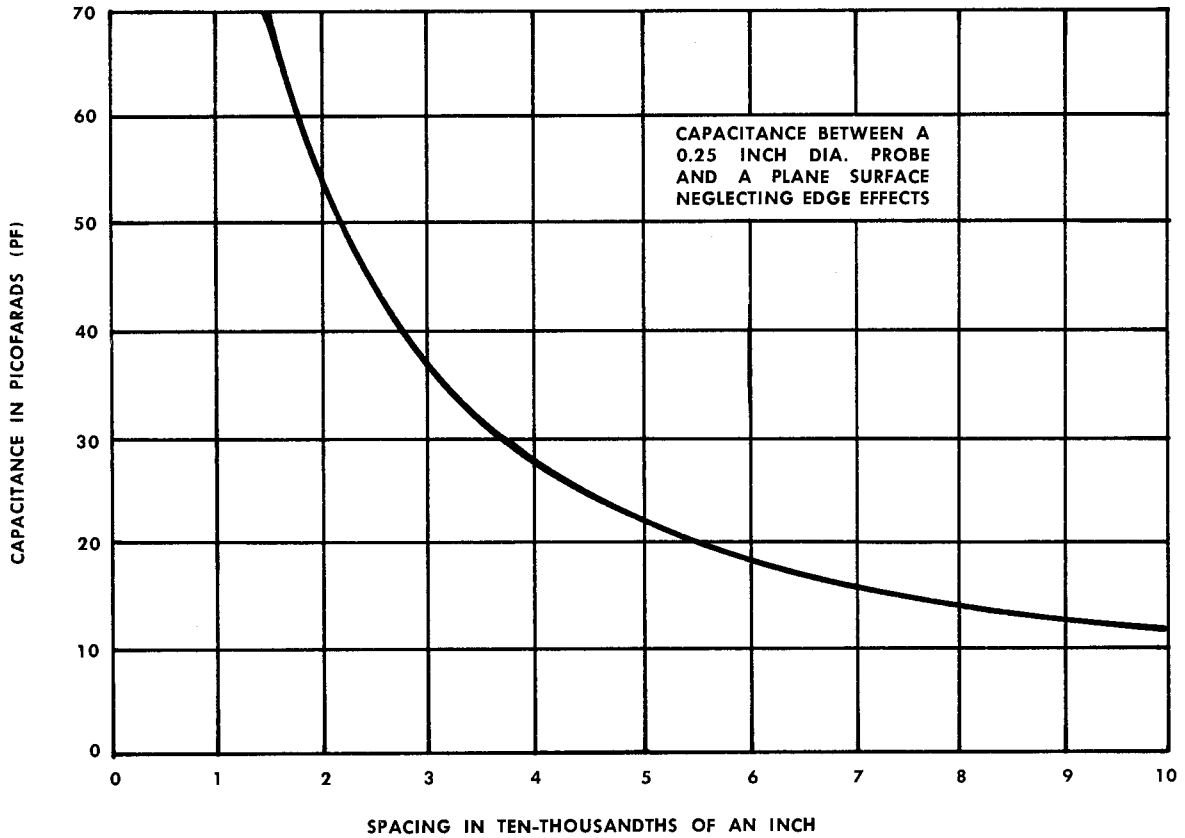

Fig. 3-6. Graphical display of capacitance versus spacing for a 1/4-inch diameter probe.

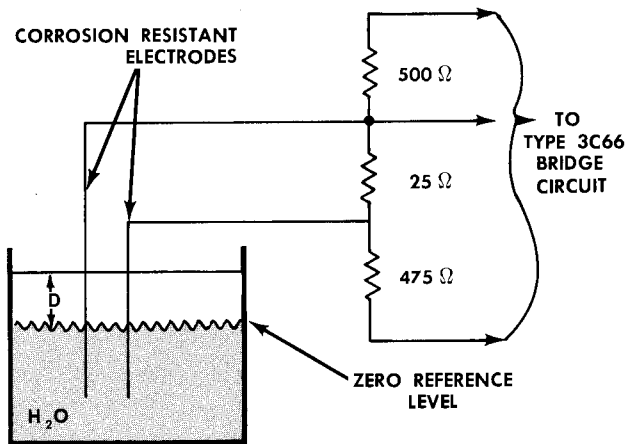

Fig. 3-7. Diagram of simple transducer for measuring water-wave actions in hydraulic model studies.

### Capacitance Measurement

A secondary application for the Type 3C66 is the direct measurement of capacitance. It can be used to measure and select capacitors in the range from 0.5 to 10,000 pf. The

connection to the capacitor under test is made with a short length of shielded lead terminated in alligator clips, or a special test jig can be used. Use pins C and D of the EXT ARMS connector to make connections to the capacitor under test. Use pin D for the ground lead.

Other than the test lead or fixture, no other equipment is needed external to the Type 3C66. Be sure the internal 120-ohm resistor is in place and the EXT ARMS switch is set to the 0 position. Replace the calibration resistor (R5) with an accurate capacitor suitable for securing a calibration point within the designed range of capacitance measurements. Using the internal resistive bridge, the normal sensitivity of the amplifier is such that the number of pf/div will be one-tenth of the calibration numerals on the  $\mu$ STRAIN/DIV switch. For example, with this switch at 100, the Type 3C66 will calibrate to 10 pf/div. Suppose you select an accurate 40-pf capacitor for calibration purposes. Then, in the 100 position of the  $\mu$ STRAIN/DIV switch, adjust the GAIN control for 4 divisions of deflection when the CALIBRATE switch is at -400. The PHASE control will have to be adjusted until the trace deflection is maximum for a capacitive-type bridge unbalance before completing the gain adjustment. If greater capacitance sensitivity is required, use an external 1000-ohm four-arm bridge to extend the useful range to 0.2 pf/div.

You can now make measurements up to 1000 pf within the accuracy limits of the  $\mu$ STRAIN/DIV switch without re-

## Applications — Type 3C66

calibrating when you change ranges. The deflection on the oscilloscope is directly proportional to the unknown capacitance. At about 1000 pf the output of the bridge is slightly nonlinear with capacitance changes. In the range above

1000 pf, the error due to nonlinearity would typically be 2% or less for a total range of 10,000 pf if you calibrate at or near full scale.

# SECTION 4

## CIRCUIT DESCRIPTION

### General Information

The carrier system used in the Type 3C66 has many advantages over a dc system. Since only ac voltages are amplified, an ac-coupled amplifier with high gain and almost zero drift is used. The modulation system has a bandpass of dc to 5 kc that allows both static and dynamic strain measurements. Because the amplifier is designed to pass a specific band of frequencies, most of the stray pickup is eliminated. One additional advantage of the ac carrier system is the use of capacitive and inductive transducers.

### Block Diagram

The block diagram for the Type 3C66 is shown in Fig. 4-1. The input circuit is an ac bridge with an external transducer connected into one or more of the bridge arms. Excitation voltage for the bridge is supplied by a 25-kc oscillator.

Under no-signal conditions, the bridge is balanced and the carrier output to the amplifier is suppressed. When the bridge is unbalanced by a change in one of the arms, sidebands are produced. The amplitude of the sidebands depends on the amount of unbalance. The phase of the sidebands depends on the direction and type of unbalance (resistive or reactive).

The sidebands from the bridge circuit are applied through a filter network to the ac amplifier. Unwanted frequencies are rejected while the sidebands are amplified. An attenuator and gain control set the overall sensitivity of the unit.

The amplified sidebands are then applied to a phase-sensitive demodulator. The other input to the demodulator is a 25-kc carrier (derived from the oscillator). The output of the demodulator passes through a filter where the unwanted modulation components are eliminated. The de-

modulated signal is then applied to the output circuit, which drives the vertical plates of the oscilloscope. This signal corresponds exactly to the variations applied to the input bridge from an external transducer.

### Input Bridge Circuit

Signals to the input bridge are in the form of impedance changes. These changes can be resistive, capacitive, inductive, or a combination of these. Since an external transducer is effectively an impedance in one or more arms of the bridge, any change to the transducer will change the bridge impedance. The bridge is designed to sense any change in arm impedance and produce an electrical output in proportion to the impedance change. The amplitude of the bridge output signal depends on the impedance changes within the arms of the bridge.

When the bridge is balanced (no-signal) the 25-kc excitation voltage is suppressed and no bridge output signal is present. Because the excitation voltage is ac, both resistive and reactive circuits are needed for complete bridge balance. The resistive balance circuit compensates for both resistance difference between transducers and resistance in leads. Unbalance of the bridge due to either capacitive or inductive reactance is  $90^\circ$  out of phase with the resistive component, thus a separate capacitive balance circuit is used. From Fig. 4-2 it can be seen that to balance the bridge resistively, the ratio of R2 to R4 must equal the ratio of R6 to R8. The resistive balance controls adjust the ratio of R6 to R8 to produce a balanced condition. To obtain capacitive balance, the ratio of the arm 2 capacitance to the arm 1 capacitance must equal the ratio of the arm 3 capacitance to the arm 4 capacitance. The capacitive balance controls adjust the capacitance ratio on the left side of the bridge to equal the capacitance ratio on the right.

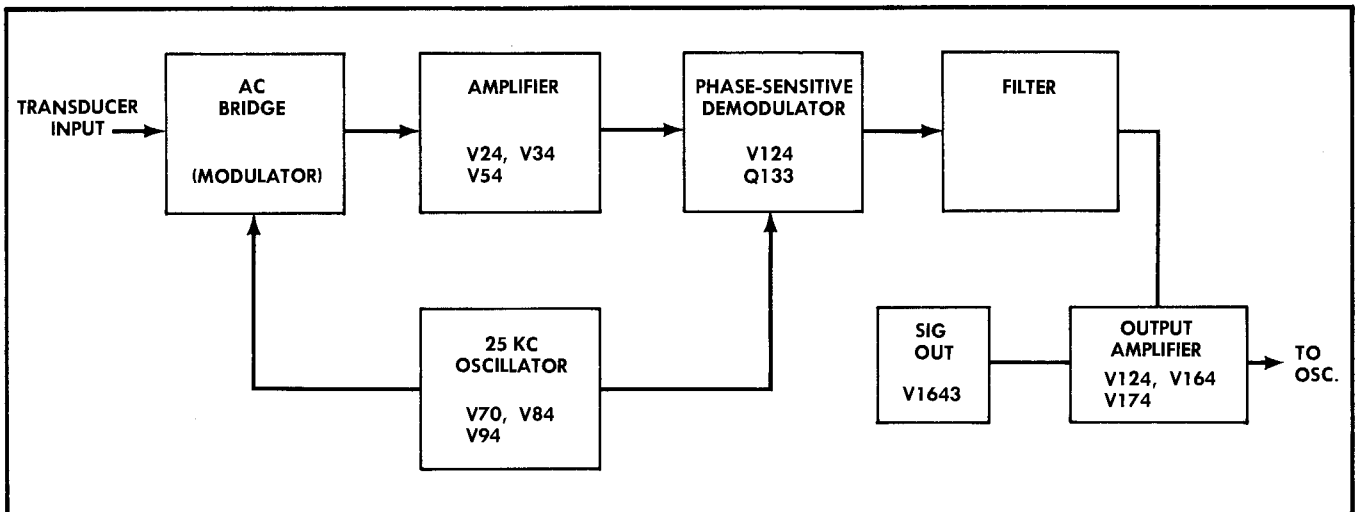

Fig. 4-1. Type 3C66 block diagram.

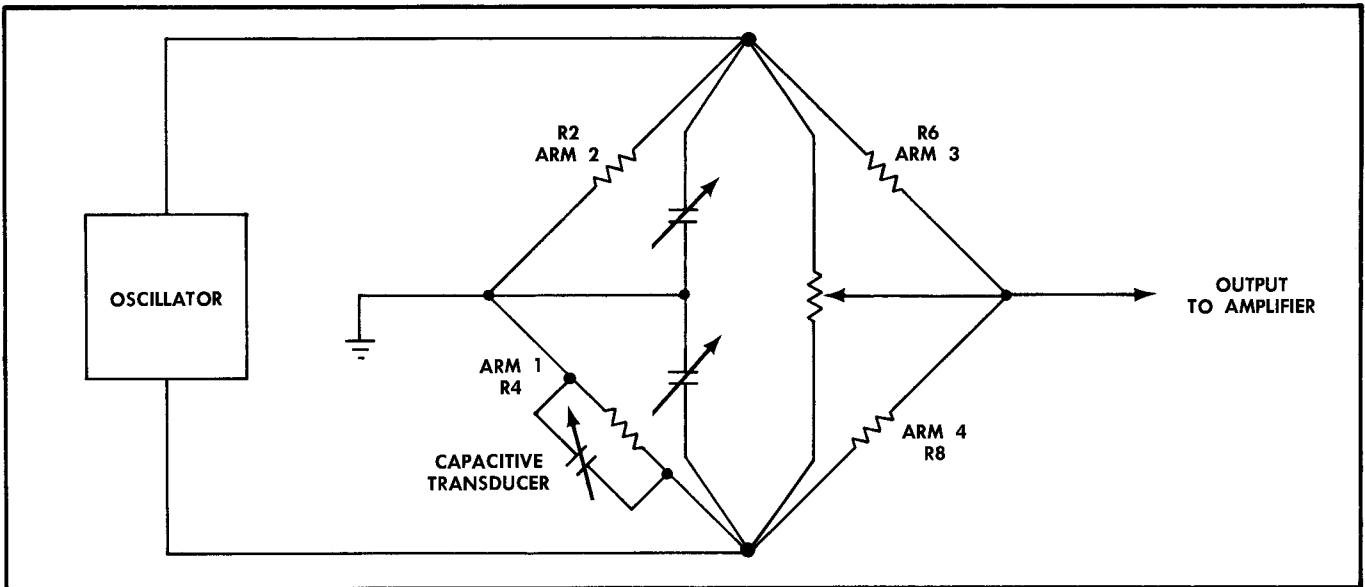

Fig. 4-2. Simplified Bridge schematic showing Bridge Balance circuits.

Under perfect balance conditions, the 25-kc carrier is suppressed and no output is obtained from the bridge. When a transducer is activated, impedance changes cause the bridge to unbalance and modulate the 25-kc carrier. This produces output sidebands which are the sum and difference of the impedance change and the carrier frequency. For example, if the transducer is activated by a 1-kc vibration, the sideband frequencies will be 24 kc and 26 kc. If the transducer is activated by a static force (zero frequency), the output of the bridge will be only 25 kc. The amplitude of the bridge output signal is directly proportional to the amount of bridge unbalance. The phase of the output signal is determined by the type of unbalance. Capacitive unbalance is approximately  $90^\circ$  out of phase with any resistive unbalance. Usually resistive and capacitive unbalance do not occur at the same time. The phase angle of the bridge output signal is usually  $0^\circ$ ,  $90^\circ$ ,  $180^\circ$ , or  $270^\circ$  with respect to the carrier. The upper and lower sidebands at the output of the bridge are applied to the ac amplifier through L20 and C21.

To produce a definite amount of bridge unbalance for calibration, a special circuit is used. This consists of CALIBRATE switch SW10, resistor R5, and capacitor C5. When the switch is turned to  $-400$ , R5 is connected in parallel with external arm 1 of the bridge. This causes a resistance change in the bridge arm that corresponds to a  $-400\text{-}\mu\text{strain}$  signal. The resultant output signal from the bridge is used to set the PHASE and GAIN controls. When reactive transducers are used, reactive components may be used in place of R5 to produce the correct calibration signal. When the CALIBRATE switch is at  $-400$ , a small amount of stray capacitance is connected in parallel with external arm 1. This stray capacitance produces a capacitive unbalance in addition to the resistive unbalance. To eliminate this effect, C5 is connected in parallel with the arm when the switch is set to NORM. This capacitor is adjusted so the same amount of capacitance exists in both positions of the switch. The small amount of capacitance is then balanced out with the capacitive balance controls. Since the same amount of capaci-

tance exists in both positions of the switch, no capacitive unbalance is introduced when the CALIBRATE switch is turned to  $-400$ . The bridge then sees a pure resistive unbalance.

### Oscillator Circuit

The oscillator circuit V70 produces the excitation voltage for the bridge and the carrier voltage for the phase-sensitive demodulator. The push-pull output of the oscillator is applied directly to the grids of V84A and V84B. The output of this amplifier is then applied to the primary winding of T84. One secondary winding of T84 supplies the bridge excitation voltage while the other passes through a phase-shifting network to the phase-sensitive demodulator. The output amplitude of the oscillator is held constant by a feedback regulator network V94.

### Amplifier Circuit

Sidebands from the bridge are applied through a filter network (L20 and C21) to the grid of amplifier V24A. The filter rejects high-frequency pickup but allows the sidebands to pass with little attenuation. The signal is amplified by V24A and applied through cathode follower V24B to the  $\mu\text{STRAIN/DIV}$  attenuator. The selected signal is amplified by V34A and B and applied to the grid of V54A. A twin-tee filter between the grid of V54A and the cathode of V34A presents low impedance to frequencies above and below the sideband frequencies, but presents high impedance to frequencies in the vicinity of 25 kc. Unwanted frequencies are thereby coupled back as inverse feedback which reduces the amplifier gain for these frequencies.

The plate output of V54A is amplified by V54B and connected through C58 and the 75-kc rejection filter to the FUNCTION switch. A degenerative feedback network is connected between the plate circuit V54B and the cathode of V54A. The impedance of C56 is quite low at 25 kc so that

at this frequency R57 is bypassed to ground. Thus, the amount of feedback depends on the ratio of R60 and R61 in series with the parallel resistance of R55 and R57. Both VARIABLE control R55 and GAIN control R61 affect this ratio and thus the amount of feedback. The VARIABLE control produces an additional effect on the gain of V54A by varying the cathode resistance of the stage.

### 75-Kc Notch Filter

L66, C66, and R66 form a notch filter for third harmonics of the 25-kc oscillator frequency.

### Phase Sensitive Demodulator

In the demodulator, the carrier is first added to the sidebands. The resulting modulation envelope is then demodulated and applied through a filter to the output stage. The sidebands are applied from the output of the amplifier while the carrier is applied from the oscillator through a phase-shifting network. The sidebands are coupled to the primary of T110 from the cathode of V104A, and the carrier is connected to the center-tapped secondary of T110 from the cathode of V104B.

The upper and lower sections of the secondary of T110 are diode demodulators. Thus, when the carrier voltage at the center tap goes positive, D111 is forward biased and C111 is charged by the positive half-cycle of the carrier. On the negative cycle, D112 is forward biased and the peak negative voltage charges C112. Thus, the peak-to-peak voltage appears across R111 and R112. Since these two resistors are of equal value, the voltage at their junction is zero. When the sidebands pass through the primary of T110, they are coupled into the secondary and combine with the carrier. If the POLARITY switch is in the NORM position, the phase of the sidebands adds to the negative cycle and subtracts from the positive cycle of the carrier. The effect is to increase the negative voltage across R112 and reduce the positive voltage across R111. Thus, the junction of R111 and R112 goes negative. This change is coupled through cathode follower V124A and the filter networks to the output amplifier.

If the POLARITY switch is set to INV, the sidebands add to the positive cycle of the carrier and the output voltage to the grid of V124A is positive.

To obtain maximum sensitivity from the demodulator, the phase relationship between the carrier and the sidebands should be either 0 or 180°. The front-panel PHASE control adjusts the carrier phase to meet this requirement.

### Filter and Output Amplifier

Cathode follower V124A serves as a buffer between the demodulator and the filter network. Q133 couples the signal from V124A to the filter. Q133 has a low output impedance and sufficient dynamic range to maintain linearity of the signal through the required voltage swing. The filter consists of two parallel LC networks with a pi-section between. The response of this combined network is shown in Fig. 4-3.

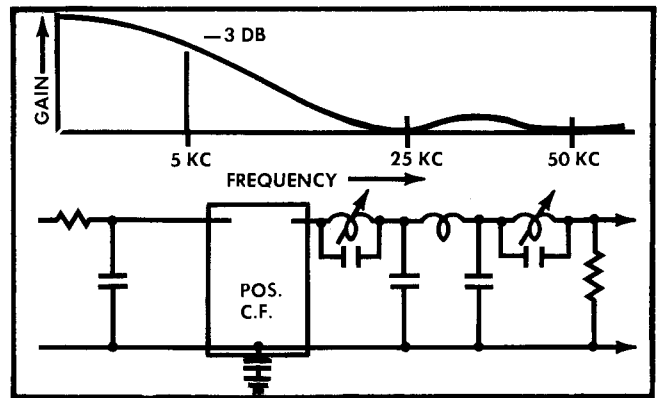

Fig. 4-3. Response curve and simplified schematic for the filter network.

The signal, devoid of high-frequency components, is applied to the grid of V124B. V124B and V164A form a cathode-coupled paraphase amplifier. This stage produces a push-pull signal to drive output stage V174A and B and the crt vertical deflection plates. A portion of the output signal is coupled through cathode-follower V164B for the SIG OUT jack on the front panel and to the time-base circuitry for a trigger signal. R167 (SIG OUT DC LEVEL) sets this signal level.





# SECTION 5

## MAINTENANCE

### PREVENTIVE MAINTENANCE

#### Visual Inspection

The Type 3C66 should be inspected occasionally for visible defects such as poor connections, broken or damaged ceramic strips, improperly seated tubes or transistors, and heat-damaged parts. The remedy for most defects is obvious; however, particular care must be taken if heat-damaged parts are detected. Overheating can be caused by other, less apparent troubles in the circuit. Find the actual cause of overheating before the parts are replaced; otherwise, the damage may be repeated.

#### Recalibration

The Type 3C66 is a stable instrument and should provide many hours of trouble-free operation. To maintain measurement accuracy, we suggest a calibration check after each 500 hours of operation (or every six months if used intermittently). Complete calibration instructions are contained in Section 6 of this manual. The calibration procedure also includes steps which will help check for proper operation of various circuits. Minor troubles not apparent during regular operation will often be found during calibration. Also, trouble in the instrument can often be isolated or eliminated by calibrating the instrument.

### PARTS REPLACEMENT

#### General Information

Replacement procedures for most parts in the instrument are obvious. However, some parts require special techniques. Replacement of these parts is described in the following paragraphs.

Some components in the instrument are mounted in a special way to reduce stray inductance and capacitance. When you replace any component, try to duplicate lead length, lead dress, and location of the original component.

After a part has been replaced, check the calibration of the instrument. Parts of the same type may have slightly different characteristics that will affect calibration.

#### Tubes and Transistors

Tubes or transistors should not be replaced unless they are actually defective. If they are removed and found to be acceptable, be sure to return them to their original sockets. This avoids recalibration due to different tube or transistor characteristics.

A good way to check tubes or transistors is by substitution. That is, replace the suspected tube or transistor with one of the same type that you know is good. Then, check to see if the instrument operates properly. If not, return the original tube or transistor to its socket.

#### Wafer Switches

Individual wafers are usually not replaced in the switch assemblies. If one wafer is defective, the entire switch assembly should be replaced. Switches can be ordered from Tektronix either wired or unwired.

The wafer switches shown on the schematics are coded to indicate the position of the wafer on the switch. The wafers are numbered from front to rear (i.e., the number 1 wafer is always closest to the front panel). The letters F and R identify the front or rear of the wafer. For example, a code designation of 3R means the rear side of the third wafer from the front panel.

#### Solder Precautions

In the manufacture of Tektronix instruments, a silver-bearing solder is used to establish a bond to the ceramic terminal strips. This bond may be broken by repeated use of ordinary tin-lead solder, and by excessive heating of the terminal strip with a soldering iron. Occasional use of ordinary 60/40 solder is permissible if applied with moderate heat. For general repair work, however, solder used for the ceramic strips should contain about 3% silver. If this type of solder is not available locally, it may be purchased from Tektronix in one-pound rolls (part number 251-514).

A wedge-shaped tip on the soldering iron is best for soldering or unsoldering parts on the ceramic strip. This type of tip allows you to apply heat directly to the solder-slot on the strip, reducing the overall heating effect. Use as little heat as possible to establish a good solder bond.

The following procedure is recommended for soldering and unsoldering short-lead components: (1) Use long-nose pliers for a heat sink. Attach the pliers between the component and the point where the heat is applied. (2) Use a hot soldering iron for a short time. (3) Carefully manipulate the leads to prevent lead or insulation damage. (4) Use only a small amount of solder; just enough to make a good bond.

#### Ceramic Terminal Strips

To remove a ceramic terminal strip, first unsolder all leads and components connected to it. Then pry the strip, with yokes attached out of the chassis. The spacers may come out with the yokes; if not, they can be pulled out separately. If they are not damaged, the spacers may be used with the new strip assembly.

Another way to remove a strip from the chassis is to use diagonal cutters to cut off one side of each yoke holding the strip. This frees the strip, and the remainder of the yokes can then be pulled free of the chassis with a pair of pliers. Ceramic strips are supplied with yokes attached so it is not necessary to salvage the old yokes.

After removing a damaged strip and yoke assembly, place the spacers into the holes in the chassis and insert the yokes into the spacers. Be sure the yokes are completely seat-

## Maintenance — Type 3C66

ed in the spacers. If necessary, use a soft-faced mallet to tap the yokes into the spacers. Fig. 5-1 shows the assembled ceramic strip.

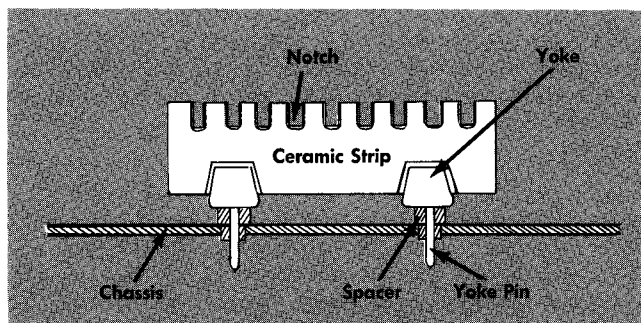

Fig. 5-1. Ceramic strip assembly.

## TROUBLESHOOTING

### General Information

If trouble develops in the Type 3C66, first check for proper control settings. A control set to the wrong position may produce an apparent trouble symptom. Improper calibration can also cause faulty operation. By attempting to calibrate the instrument, trouble may be isolated to a given circuit; if the trouble is due to improper calibration, the trouble will be corrected.

Unusual troubles can be caused by a failure in one of the oscilloscope power supplies. This should be considered any time the instrument fails to operate properly. The oscilloscope manual contains information for checking power supply voltages.

If you suspect that a tube or transistor in the instrument is defective, replace it with a good tube or transistor of the same type. Then check to see if the trouble symptom is eliminated. If not, the original tube or transistor is probably good, and should be returned to its original socket.

# SECTION 6

## CALIBRATION

### General Information

The steps that follow are arranged in sequence for a complete calibration of the Type 3C66. This sequence should be followed to avoid repetition of checks and adjustments.

### Equipment Required

1. Tektronix Type 560-Series oscilloscope (except the Type 560 itself).
2. Tektronix '2'- or '3'-Series time-base plug-in unit.
3. Test oscilloscope: Bandwidth at least 100 kc with 0.05-volt sensitivity, dc coupled.
4. Audio Generator: Frequencies to 100 kc, at least 1 volt peak-to-peak output.
5. One 150-k calibration resistor (supplied with unit).
6. One 120-ohm internal bridge resistor (supplied with unit).
7. Tektronix Type 561 Plug-In Extension, part no. 013-034.

### PRELIMINARY PROCEDURE

Insert the Type 3C66 (on the plug-in extension) in the left-hand compartment of a Type 560-Series oscilloscope, and a '2'- or '3'-Series time-base plug-in unit in the right hand compartment.

Plug the 150-k calibration resistor and the 120-ohm internal bridge resistor into the Type 3C66. Turn the oscilloscope on and allow a 15-minute warmup. Adjust the oscilloscope controls for automatic triggering at a sweep rate of 20  $\mu$ sec/div.

Set the front-panel controls as follows:

EXT ARMS	O
CALIBRATE	NORM
VARIABLE	CALIB
POLARITY	NORM

### ADJUSTMENT PROCEDURE

The test points and adjustment locations are shown in Figs. 6-1 and 6-2.

#### 1. Vertical Position Range

This adjustment brings the POSITION control into proper range. To make the adjustment, set the FUNCTION switch to INST ZERO and the POSITION control to midrange. Adjust the POSITION RANGE control R85 to center the trace on the crt.

#### 2. Oscillator Frequency

The frequency of the Type 3C66 oscillator is adjusted by means of L70. When the coil is properly adjusted, the oscillator frequency is 25 kc  $\pm$ 5%.

Set the FUNCTION switch to BALANCE, and set the BRIDGE BALANCE switches for approximately 3 divisions of vertical deflection. Adjust L70 to obtain 5 cycles per 10 divisions on the oscilloscope. It may be necessary to reset the BRIDGE BALANCE switches as this adjustment is made to maintain the desired signal amplitude.

#### 3. Capacitor C5

Capacitor C5 is used to insure that no unwanted capacitive bridge unbalance is introduced when the CALIBRATE switch is set to  $-400$ . When properly adjusted, equal amounts of capacitance will be introduced in one bridge arm in either position of the CALIBRATE switch.

Set the FUNCTION switch to OPERATE. Remove the 150-k calibration resistor from the unit and balance the bridge circuit. Set the  $\mu$ STRAIN/DIV switch to 10 and the VARIABLE control to CALIB. Set the CALIBRATE switch to  $-400$  and adjust C5 until minimum vertical trace shift occurs at either position of the CALIBRATE switch.

#### 4. Phase

Complete instructions for setting the front-panel PHASE control are contained in the Operating Instructions section of this manual. However, for convenience, a portion of this procedure is repeated here. Under normal conditions, the PHASE control is set with the transducer connected to the unit. The procedure described here is only for use with the internal bridge circuit.

The primary reason for setting the PHASE control is to insure that the carrier is added to the sidebands in the demodulator circuit in the proper phase. This adjustment must be made before adjusting the filter traps in the following steps.

Replace the 150-k calibration resistor. Set the FUNCTION switch to BALANCE, and balance the bridge. Set the  $\mu$ STRAIN/DIV switch to 100 and the VARIABLE control to CALIB. Set the FUNCTION switch to OPERATE and set the CALIBRATE switch to  $-400$ . Adjust the PHASE control to obtain maximum downward deflection of the crt trace.

#### 5. Gain

Complete information for setting the front-panel GAIN control is contained in the Operating Instructions section of this manual and only adjustment with the internal bridge circuit will be covered here. In this procedure, calibration is made for a 120-ohm strain gage with a gage factor of 2.

Set the FUNCTION switch to OPERATE. The GAIN control is set to provide the correct amount of vertical-trace deflection for a given amount of strain. To make the adjustment, set the  $\mu$ STRAIN/DIV switch to 100 and the VARIABLE control to CALIB. Adjust the PHASE control as described in step 4. Adjust the GAIN control for exactly 4 major graticule divisions of vertical deflection.

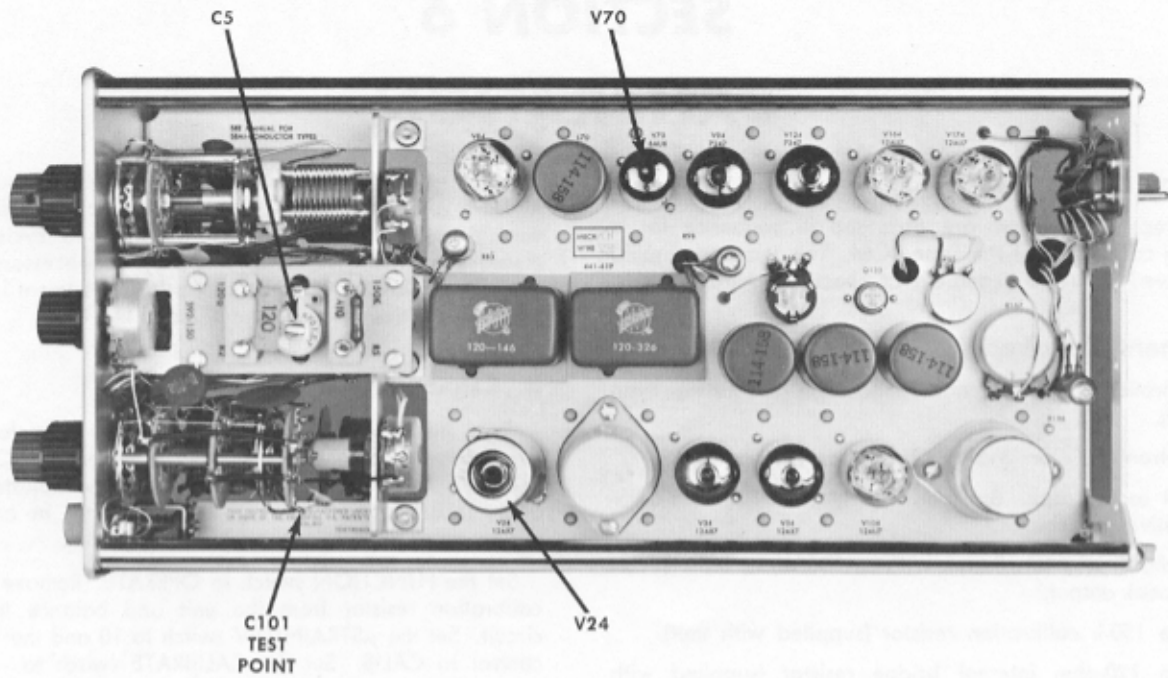

Fig. 6-1. Right side view.

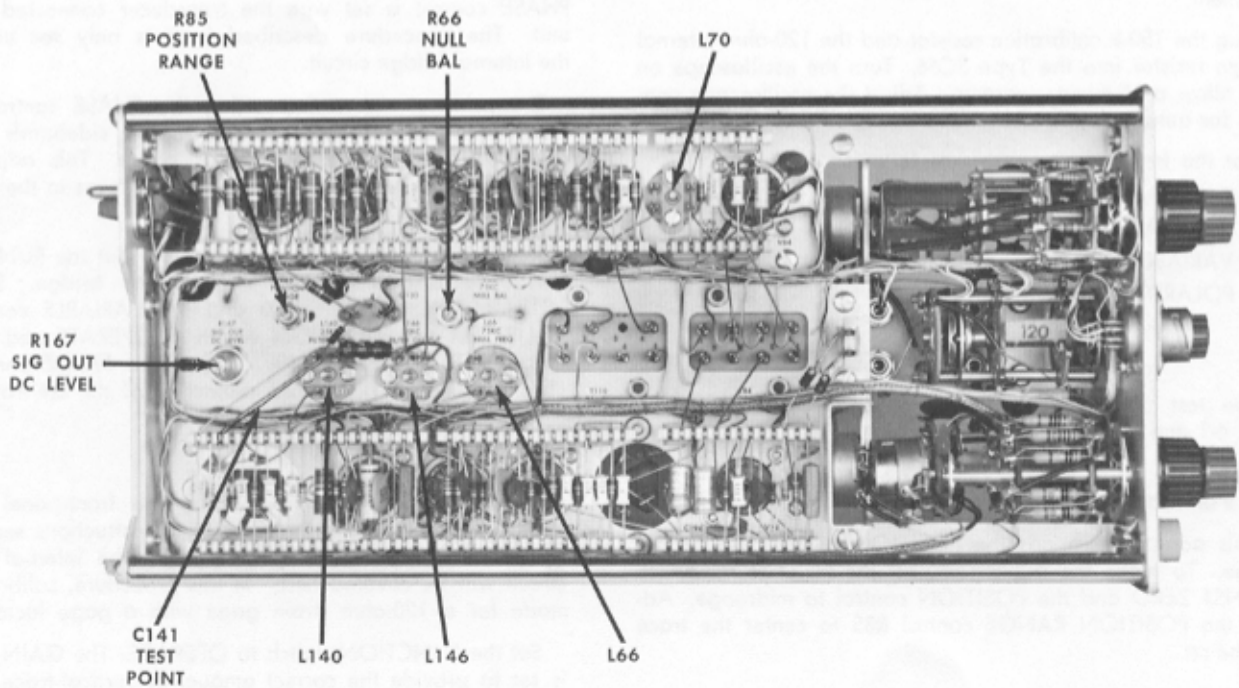

Fig. 6-2. Left side view.

## 6. First 25-Kc Filter Trap

Connect the test oscilloscope to the C141 test point. Set the FUNCTION switch to OPERATE and turn the BRIDGE BALANCE switches fully clockwise. Adjust L140 for minimum 25-kc signal.

## 7. Second 25-Kc Filter Trap

To further eliminate 25-kc components appearing in the output of the Type 3C66, a 25-kc filter consisting of L146 and C146 is used. The circuit is tuned by means of L146 to a resonant point at 25 kc.

Set the FUNCTION switch to BALANCE and the BRIDGE BALANCE switches for approximately 3 divisions of deflection. Adjust L146 for maximum amplitude of the displayed signal. If necessary, set the BRIDGE BALANCE switches to keep the signal on the crt.

## 8. 75-Kc Filter Trap

Remove oscillator tube V70. Apply a 1- to 3-volt 75-kc signal from an audio generator to pin 2 of V24. Connect the test oscilloscope to the C101 test point and adjust L66 and R66 (NULL BAL) for minimum signal.

### NOTE

If maximum third-harmonic suppression is needed, adjust the audio generator frequency to the third harmonic of the Type 3C66 oscillator frequency using Lissajous patterns.

## 9. Output Dc Level

Set the FUNCTION switch to INST ZERO. Position the trace to the center of the crt. Connect the test oscilloscope (dc coupled) to the SIG OUT connector. Adjust R167 (SIG OUT DC LEVEL) for zero volts.



# SECTION 7

## PARTS LIST AND SCHEMATICS

### PARTS ORDERING INFORMATION

Replacement parts are available from or through your local Tektronix Field Office.

Changes to Tektronix instruments are sometimes made to accommodate improved components as they become available, and to give you the benefit of the latest circuit improvements developed in our engineering department. It is therefore important, when ordering parts, to include the following information in your order: Part number including any suffix, instrument type, serial number, and modification number if applicable.

If a part you have ordered has been replaced with a new or improved part, your local Tektronix Field Office will contact you concerning any change in part number.

### ABBREVIATIONS AND SYMBOLS

a or amp	amperes	mm	millimeter
BHS	binding head steel	meg or M	megohms or mega (10 <sup>6</sup> )
C	carbon	met.	metal
cer	ceramic	μ	micro, or 10 <sup>-6</sup>
cm	centimeter	n	nano, or 10 <sup>-9</sup>
comp	composition	Ω	ohm
cps	cycles per second	OD	outside diameter
crt	cathode-ray tube	OHS	oval head steel
CSK	counter sunk	p	pico, or 10 <sup>-12</sup>
dia	diameter	PHS	pan head steel
div	division	piv	peak inverse voltage
EMC	electrolytic, metal cased	plstc	plastic
EMT	electrolytic, metal tubular	PMC	paper, metal cased
ext	external	poly	polystyrene
f	farad	Prec	precision
F & I	focus and intensity	PT	paper tubular
FHS	flat head steel	PTM	paper or plastic, tubular, molded
Fil HS	fillister head steel	RHS	round head steel
g or G	giga, or 10 <sup>9</sup>	rms	root mean square
Ge	germanium	sec	second
GMV	guaranteed minimum value	Si	silicon
h	henry	S/N	serial number
hex	hexagonal	t or T	tera, or 10 <sup>12</sup>
HHS	hex head steel	TD	toroid
HSS	hex socket steel	THS	truss head steel
HV	high voltage	tub.	tubular
ID	inside diameter	v or V	volt
incd	incandescent	Var	variable
int	internal	w	watt
k or K	kilohms or kilo (10 <sup>3</sup> )	w/	with
kc	kilocycle	w/o	without
m	milli, or 10 <sup>-3</sup>	WW	wire-wound
mc	megacycle		

### SPECIAL NOTES AND SYMBOLS

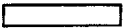
X000	Part first added at this serial number.
000X	Part removed after this serial number.
*000-000	Asterisk preceding Tektronix Part Number indicates manufactured by or for Tektronix, or reworked or checked components.
Use 000-000	Part number indicated is direct replacement.
	Internal screwdriver adjustment.
	Front-panel adjustment or connector.

EXPLODED VIEW

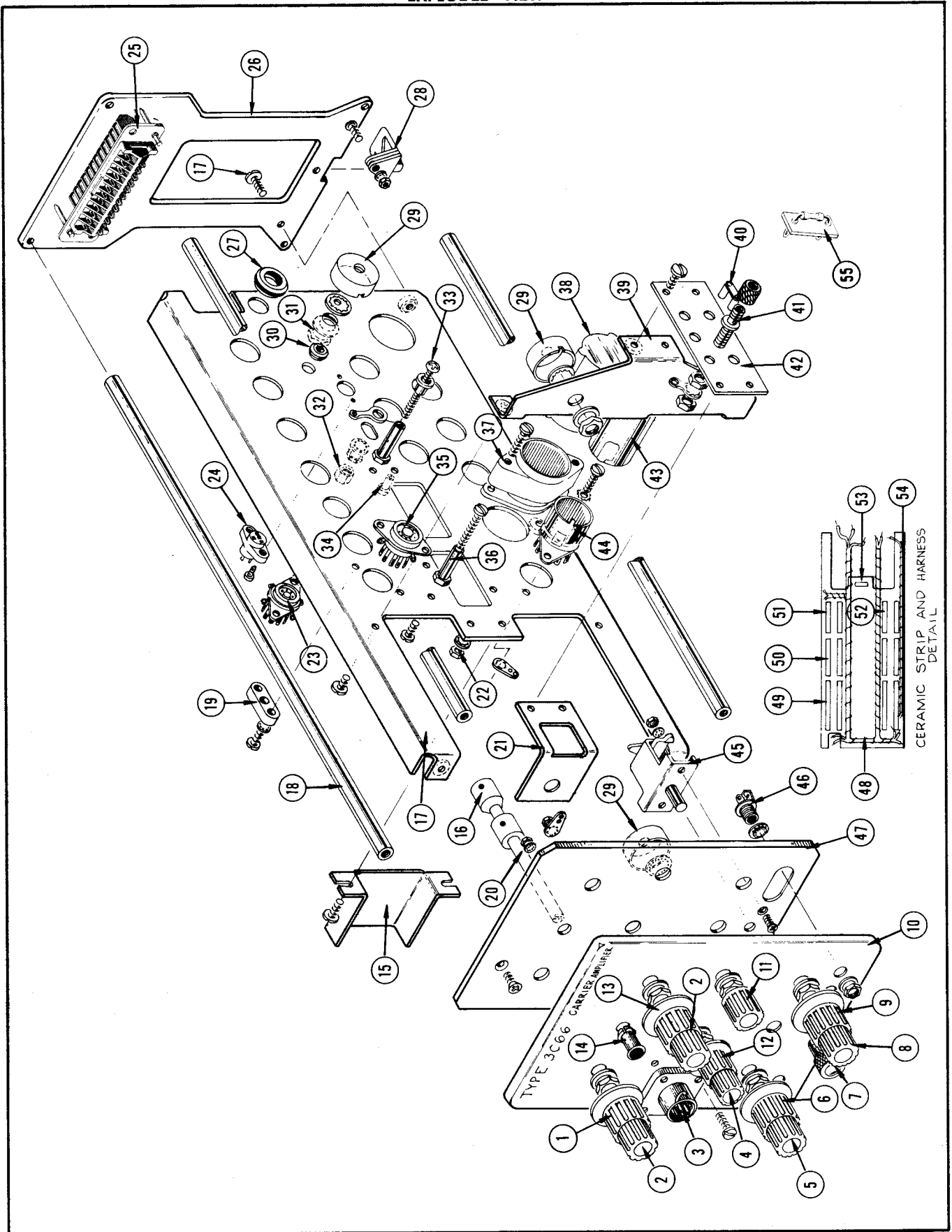



## EXPLODED VIEW

REF. NO.	PART NO.	SERIAL/MODEL NO.		QTY.	DESCRIPTION
		EFF.	DISC.		
1	366-0142-00			1	KNOB, RESISTANCE, large charcoal
2	366-0031-00			2	KNOB, FINE, small red
3	136-0077-00			1	SOCKET, 9 pin chassis
	-----			-	Mounting Hardware: (not included)
	211-0012-00			4	SCREW, 4-40 x 3/8 inch BHS
	210-0004-00			3	LOCKWASHER, internal, #4
	210-0201-00			1	LUG, solder, SE4
	210-0406-00			4	NUT, hex, 4-40 x 3/16 inch
4	366-0081-00			1	KNOB, CALIBRATE, small red
5	366-0031-00			1	KNOB, VARIABLE, small red
6	366-0142-00			1	KNOB, μSTRAIN/DIV, large charcoal
7	366-0109-00			1	KNOB, plug-in securing
8	366-0031-00			1	KNOB, POLARITY, small red
9	366-0142-00			1	KNOB, FUNCTION, large charcoal
10	333-0683-00			1	PANEL, front
11	366-0148-00			1	KNOB, POSITION, charcoal
12	366-0156-00			1	KNOB, EXT ARMS, large charcoal
13	366-0142-00			1	KNOB, CAPACITANCE, large
14	358-0178-00	100	1049	2	BUSHING, front panel, charcoal
	358-0216-00	1050		2	BUSHING, front panel, gray
15	337-0590-00			1	SHIELD, tube
16	376-0011-00			2	COUPLING, pot
	-----			-	Each includes:
	213-0048-00			2	SCREW, set, 4-40 x 1/8 inch HSS allen head
17	441-0459-00	100	1149	1	CHASSIS
	441-0459-01	1150		1	CHASSIS
	-----			-	Mounting Hardware: (not included)
	211-0538-00			2	SCREW, 6-32 x 5/16 inch FHS
	211-0507-00			3	SCREW, 6-32 x 5/16 inch BHS
18	384-0566-00			4	ROD, frame, spacing
	212-0044-00			4	SCREW, 8-32 x 1/2 inch
19	343-0098-00			4	CLAMP, coil mounting
	-----			-	Mounting Hardware For Each: (not included)
	211-0012-00			2	SCREW, 4-40 x 3/8 inch BHS
20	384-0132-00			2	ROD, extension
21	406-0869-00			1	BRACKET, support
22	-----			-	Mounting Hardware For Transformers:
	210-0407-00			4	NUT, hex, 6-32 x 1/4 inch
	210-0006-00			4	LOCKWASHER, internal, #6
23	136-0008-00			1	SOCKET, STM7G
	-----			-	Mounting Hardware: (not included)
	213-0044-00			2	SCREW, thread cutting, 5-32 x 3/16 inch PHS
24	136-0161-00	100	469	1	SOCKET, 3 pin transistor
	136-0181-00	470		1	SOCKET, 3 pin transistor
	-----			-	Mounting Hardware: (not included)
	213-0113-00	100	469	2	SCREW, thread forming, 2-32 x 5/16 inch RHS
	354-0234-00	470		1	RING, locking, transistor socket

EXPLODED VIEW

REF. NO.	PART NO.	SERIAL/MODEL NO.		QTY.	DESCRIPTION
		EFF.	DISC.		
25	131-0149-00			1	CONNECTOR, chassis mount, 24 contact
	- - - - -			-	Mounting Hardware: (not included)
	211-0008-00			2	SCREW, 4-40 x 1/4 inch BHS
	210-0004-00			1	LOCKWASHER, internal, #4
	210-0201-00			1	LUG, solder, SE4
	210-0406-00			2	NUT, hex, 4-40 x 3/16 inch
26	387-0647-00			1	PLATE, rear
27	348-0005-00			1	GROMMET, 1/2 inch
28	351-0037-00			1	GUIDE, shoe
	- - - - -			-	Mounting Hardware: (not included)
	211-0013-00			1	SCREW, 4-40 x 3/8 inch RHS
	210-0004-00			1	LOCKWASHER, internal, #4
	210-0406-00			1	NUT, hex, 4-40 x 3/16 inch
29	200-0247-00	100	539	4	COVER, pot
	200-0247-00	540		3	COVER, pot
30	348-0002-00			1	GROMMET, 1/4 inch
31	- - - - -			-	Mounting Hardware For Standard Pots:
	210-0413-00			4	NUT, hex, 3/8-32 x 1/2 inch
	210-0012-00			3	LOCKWASHER, internal, 3/8 x 1/2 inch
	210-0840-00			4	WASHER, .390 ID x 9/16 inch OD
32	- - - - -			-	Mounting Hardware For Small Pots:
	210-0583-00			2	NUT, hex, 1/4-32 x 5/16 inch
	210-0940-00			2	WASHER, 1/4 ID x 3/8 inch OD
	210-0223-00			1	LUG, solder, 1/4 inch
33	- - - - -			-	Mounting Hardware For 5-10 W resistors:
	211-0553-00			1	SCREW, 6-32 x 1 1/2 inch RHS phillips
	210-0601-00			1	EYELET
	210-0478-00			1	NUT, hex, 5-10 W resistor
	211-0507-00			1	SCREW, 6-32 x 5/16 inch BHS
34	348-0031-00			5	GROMMET, poly. snap-in
35	136-0015-00			8	SOCKET, STM9G
	213-0044-00			2	Mounting Hardware For Each: (not included) SCREW, thread cutting, 5-32 x 3/16 inch PHS phillips
36	- - - - -			-	Mounting Hardware For 5-10 W resistors:
	211-0544-00			2	SCREW, 6-32 x 3/4 inch Truss HS phillips
	210-0478-00			2	NUT, Hex, 5-10 W resistor
	211-0507-00			2	SCREW, 6-32 x 5/16 inch BHS
37	432-0045-00			2	BASE, capacitor mounting
	386-0252-00			1	PLATE, fiber, small capacitor mounting
	386-0253-00			1	PLATE, metal, small capacitor mounting
	- - - - -			-	Mounting Hardware For Each: (not included)
	211-0532-00			2	SCREW, 6-32 x 3/4 inch FIL HS
38	200-0256-00	100	689	1	COVER, capacitor, 2 1/32 inches
	200-0532-00	690		1	COVER, capacitor, 1 19/32 inches
39	406-0870-00			1	BRACKET, pot mounting
	- - - - -			-	Mounting Hardware: (not included)
	211-0507-00			4	SCREW, 6-32 x 5/16 inch BHS
40	214-0153-00			1	FASTENER

## EXPLODED VIEW

REF. NO.	PART NO.	SERIAL/MODEL NO.		QTY.	DESCRIPTION
		EFF.	DISC.		
41	129-0053-00			4	POST, ground, assembly
	- - - - -			-	Each Consisting Of:
	355-0507-00			1	STEM, adapter
	200-0103-00			1	CAP
	210-0455-00			8	NUT, hex, 1/4-28 x 3/8 inch
	210-0223-00			4	LUG, solder, 1/4 inch
42	392-0150-00			1	BOARD, terminal
	- - - - -			-	Mounting Hardware: (not included)
	211-0008-00			4	SCREW, 4-40 x 1/4 inch BHS
43	337-0008-00			1	SHIELD, tube
44	136-0022-00			1	SOCKET, STM9, shielded base
	- - - - -			-	Mounting Hardware: (not included)
	211-0033-00			2	SCREW, 4-40 x 5/16 inch PHS, w/lockwasher
	211-0201-00			1	LUG, solder, SE4
	210-0406-00			2	NUT, hex, 4-40 x 3/16 inch
	210-0004-00			1	LOCKWASHER, internal, #4
45	214-0052-00			1	FASTENER, pawl right, w/stop
	- - - - -			-	Mounting Hardware: (not included)
	210-0406-00			2	NUT, hex, 4-40 x 3/16 inch
	210-0004-00			2	LOCKWASHER, internal, #4
46	136-0094-00			3	SOCKET
	- - - - -			-	Mounting Hardware Included:
47	387-0717-00			1	PLATE, front subpanel
48	179-0686-00			1	CABLE, harness, chassis
	179-0686-01	1150	1599	1	CABLE HARNESS, chassis
	179-0686-02	1600		1	CABLE HARNESS, chassis
49	124-0154-00			4	STRIP, ceramic, 20 notches, 3 x 7/16 inch
	361-0009-00			8	SPACER, nylon
50	124-0155-00			4	STRIP, ceramic, 16 notches, 27/16 x 7/16 inch
	361-0009-00			8	SPACER, nylon
51	124-0157-00			2	STRIP, ceramic, 9 notches, 17/16 x 7/16 inch
	361-0009-00			4	SPACER, nylon
52	124-0156-00			2	STRIP, ceramic, 13 notches, 2 x 7/16 inch
	261-0009-00			4	SPACER, nylon
53	124-0119-00			1	STRIP, ceramic, 2 notches, 5/8 x 7/16 inch
	361-0009-00			1	SPACER, nylon
54	179-0687-00			1	CABLE, harness, signal out
55	013-0025-00			1	BOARD, plug-in resistor, 120 Ω
	013-0078-00			1	BOARD, plug-in resistor, 150 k

SWITCHES

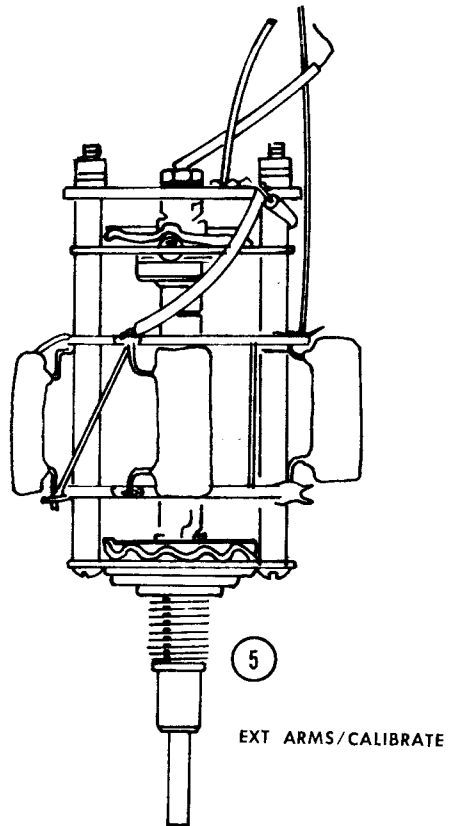
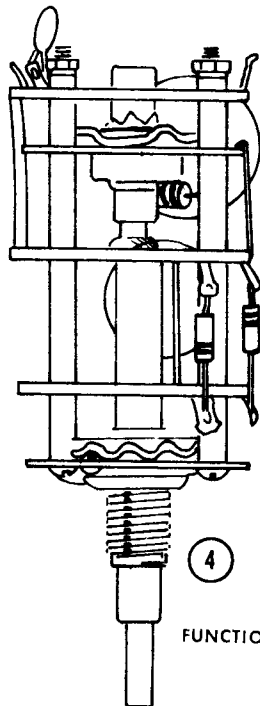
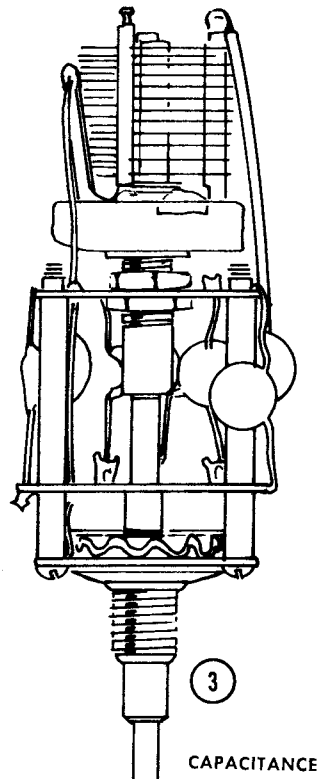
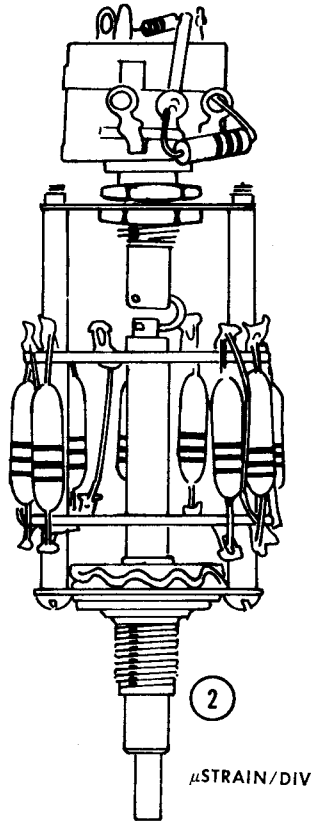
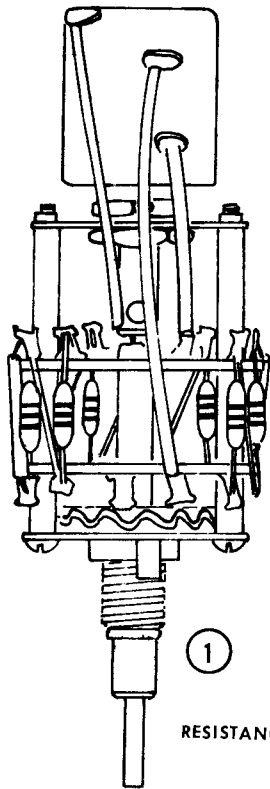

## SWITCHES

REF. NO.	PART NO.	SERIAL/MODEL NO.		QTY.	DESCRIPTION
		EFF.	DISC.		
1	262-0583-00			1	SWITCH, RESISTANCE, wired
	- - - - -			-	Includes:
	210-0413-00	100	1170X	2	NUT, hex., brass, $\frac{3}{8}$ -32 x $\frac{1}{2}$ inch
	426-0289-00	X1171		1	MOUNT, resilient
	210-0004-00	X1171		4	LOCKWASHER, external, #4
	210-0406-00	X1171		2	NUT, hex., 4-40 x $\frac{3}{16}$ inch
	210-0840-00	X1171		1	WASHER, flat, 0.390 ID x $\frac{9}{16}$ inch OD
	210-0012-00			1	LOCKWASHER, steel pot, internal $\frac{3}{8}$ x $\frac{1}{2}$ inch
	384-0289-00			1	ROD, shaft, switch, 2 $\frac{3}{16}$ inch long
	213-0004-00			1	SCREW, set, 6-32 x $\frac{3}{16}$ inch HSS
	260-0565-00	100	1170	1	SWITCH, RESISTANCE, unwired
	260-0565-01	1171		1	SWITCH, RESISTANCE, unwired
	- - - - -			-	Mounting Hardware: (not included)
	210-0413-00			1	NUT, hex., brass, $\frac{3}{8}$ -32 x $\frac{1}{2}$ inch
	210-0012-00			1	LOCKWASHER, steel, pot internal, $\frac{3}{8}$ x $\frac{1}{2}$ inch
	210-0840-00			1	WASHER, steel, .390 ID x $\frac{9}{16}$ inch OD
	2	262-0584-00			1
- - - - -				-	Includes:
384-0299-00				1	ROD, shaft, switch, 2 $\frac{3}{16}$ inch long
376-0014-00				1	COUPLING, pot, wire steel
210-0413-00				2	NUT, hex., brass, $\frac{3}{8}$ -32 x $\frac{1}{2}$ inch
210-0012-00				1	LOCKWASHER, steel pot internal, $\frac{3}{8}$ x $\frac{1}{2}$ inch
260-0564-00				1	SWITCH, $\mu$ STRAIN/DIV, unwired
- - - - -				-	Mounting Hardware: (not included)
210-0413-00				1	NUT, hex., brass, $\frac{3}{8}$ -32 x $\frac{1}{2}$ inch
210-0012-00			1	LOCKWASHER, steel, pot internal, $\frac{3}{8}$ x $\frac{1}{2}$ inch	
210-0840-00			1	WASHER, steel, .390 ID x $\frac{9}{16}$ inch OD	
3	262-0582-00			1	SWITCH, CAPACITANCE, wired
	- - - - -			-	Includes:
	260-0288-00			1	SWITCH, CAPACITANCE, unwired
	- - - - -			-	Mounting Hardware: (not included)
	210-0413-00			1	NUT, hex., brass, $\frac{3}{8}$ -32 x $\frac{1}{2}$ inch
210-0012-00			1	LOCKWASHER, steel, pot internal, $\frac{3}{8}$ x $\frac{1}{2}$ inch	
210-0840-00			1	WASHER, steel, .390 ID x $\frac{9}{16}$ inch OD	
4	262-0586-00			1	SWITCH, FUNCTION/POLARITY, wired
	- - - - -			-	Includes:
	260-0563-00			1	SWITCH, FUNCTION/POLARITY, unwired
	- - - - -			-	Mounting Hardware: (not included)
	210-0413-00			1	NUT, hex., brass, $\frac{3}{8}$ -32 x $\frac{1}{2}$ inch
210-0012-00			1	LOCKWASHER, steel, pot internal, $\frac{3}{8}$ x $\frac{1}{2}$ inch	
210-0840-00			1	WASHER, steel, .390 ID x $\frac{9}{16}$ inch OD	
5	262-0585-00			1	SWITCH, EXT ARMS/CALIBRATE, wired
	- - - - -			-	Includes:
	260-0566-00			1	SWITCH, EXT ARMS/CALIBRATE, unwired
	- - - - -			-	Mounting Hardware: (not included)
	210-0413-00			1	NUT, hex., brass, $\frac{3}{8}$ -32 x $\frac{1}{2}$ inch
210-0012-00			1	LOCKWASHER, steel, pot internal, $\frac{3}{8}$ x $\frac{1}{2}$ inch	
210-0840-00			1	WASHER, steel, .390 ID x $\frac{9}{16}$ inch OD	

STANDARD ACCESSORIES

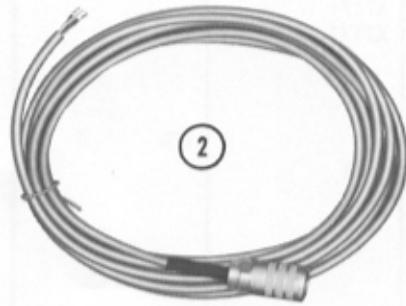
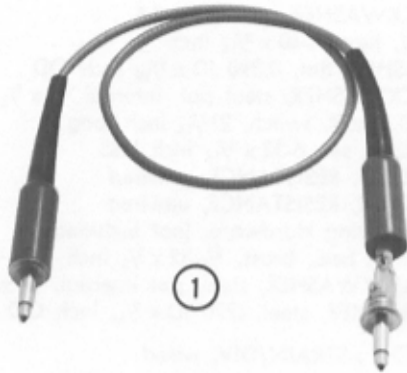

REF. NO.	PART NO.	SERIAL/MODEL NO.		QTY.	DESCRIPTION
		EFF.	DISC.		
1	012-0063-00			1	CABLE, synchronizing
2	012-0040-00			1	CABLE, inter-connecting, 4 conductor
- -	070-0357-00			2	MANUAL, instruction (not shown)

## ELECTRICAL PARTS

Values are fixed unless marked Variable.

Ckt. No.	Tektronix Part No.	Description	S/N Range
----------	--------------------	-------------	-----------

## Capacitors

Tolerance  $\pm 20\%$  unless otherwise indicated.

Tolerance of all electrolytic capacitors as follows (with exceptions):

3 V — 50 V =  $-10\%$ ,  $+250\%$ 51 V — 350 V =  $-10\%$ ,  $+100\%$ 351 V — 450 V =  $-10\%$ ,  $+50\%$ 

Ckt. No.	Tektronix Part No.	Value	Description	Var.	Var.	S/N Range
C5	281-005	1.5-7 pf	Cer.			
C10	*281-046	5-80 pf	Air			FINE
C11A	283-095	56 pf	Disc Type		200 v	10%
C11C	283-095	56 pf	Disc Type		200 v	10%
C11E	283-095	56 pf	Disc Type		200 v	10%
C11G	283-095	56 pf	Disc Type		200 v	10%
C11J	283-095	56 pf	Disc Type		200 v	10%
C11L	283-094	27 pf	Disc Type		200 v	10%
C20	283-000	.001 $\mu$ f	Disc Type		500 v	
C21	283-527	.001 $\mu$ f	Mica		500 v	5%
C23	283-068	.01 $\mu$ f	Disc Type		500 v	
C24	281-540	51 pf	Cer.		500 v	5%
C25	283-000	.001 $\mu$ f	Disc Type		500 v	
C26	290-106	10 $\mu$ f	EMT		15 v	
C29	283-003	.01 $\mu$ f	Disc Type		150 v	
C38	283-001	.005 $\mu$ f	Disc Type		500 v	
C39	283-004	.02 $\mu$ f	Disc Type		150 v	
C42	281-546	330 pf	Cer.		500 v	10%
C43	281-546	330 pf	Cer.		500 v	10%
C46	281-546	330 pf	Cer.		500 v	10%
C47	281-546	330 pf	Cer.		500 v	10%
C56	285-566	.022 $\mu$ f	PTM		200 v	10%
C58	283-001	.005 $\mu$ f	Disc Type		500 v	
C59	283-004	.02 $\mu$ f	Disc Type		150 v	
C66	283-522	470 pf	Mica		500 v	10%
C70	285-643	.0047 $\mu$ f	PTM		100 v	5%
C71	Use 281-0536-00	1000 pf	Cer.		500 V	10%
C72	281-546	330 pf	Cer.		500 v	10%
C74	283-000	.001 $\mu$ f	Disc Type		500 v	
C83	283-004	.02 $\mu$ f	Disc Type		150 v	
C85	290-106	10 $\mu$ f	EMT		15 v	
C88	285-598	.01 $\mu$ f	PTM		100 v	5%
C89	281-546	330 pf	Cer.		500 v	10%
C90	281-546	330 pf	Cer.		500 v	10%
C91	283-004	.02 $\mu$ f	Disc Type		150 v	

Parts List — Type 3C66

Capacitors (Cont'd)

Ckt. No.	Tektronix Part No.		Description		S/N Range
C94	283-003	.01 $\mu$ f	Disc Type	150 v	
C95	283-004	.02 $\mu$ f	Disc Type	150 v	
C96	Use 283-068	.01 $\mu$ f	Disc Type	500 v	
C99	283-003	.01 $\mu$ f	Disc Type	150 v	
C101	283-000	.001 $\mu$ f	Disc Type	500 v	
C105	283-004	.02 $\mu$ f	Disc Type	150 v	
C111	281-536	.001 $\mu$ f	Cer.	500 v	10%
C112	281-536	.001 $\mu$ f	Cer.	500 v	10%
C120	281-546	330 pF	Cer.	500 v	10%
C140	285-643	.0047 $\mu$ f	PTM	100 v	5%
C141	285-627	.0033 $\mu$ f	PTM	100 v	5%
C143	285-624	.027 $\mu$ f	PTM	100 v	10%
C146	285-643	.0047 $\mu$ f	PTM	100 v	5%
C149	283-019	2.2 $\mu$ f	Disc Type	3 v	
C152	281-0580-00	470 pF	Cer	500 V	10% X1540-up
C153	283-002	.01 $\mu$ f	Disc Type	500 v	
C190A,B,C	Use 290-004	3 x 10 $\mu$ f	EMC	350 v	
C194	Use 290-023	2 x 40 $\mu$ f	EMC	150 v	

Connectors

J72	136-094	Socket, SYNC IN
J90	136-094	Socket, SYNC OUT
J169	136-094	Socket, SIG OUT
P10	136-077	Socket, 9 pin

Diodes

D26	152-008	Germanium T12G		100-1069
D26	*152-0185-00	Silicon	Replaceable by 1N4152	1070-up
D91	152-005	Germanium T13G		100-1069
D91	*152-0185-00	Silicon	Replaceable by 1N4152	1070-up
D111	152-008	Germanium T12G		100-1069
D111	*152-0185-00	Silicon	Replaceable by 1N4152	1070-up
D112	152-008	Germanium T12G		100-1069
D112	*152-0185-00	Silicon	Replaceable by 1N4152	1070-up

Inductors

L20	108-226	100 $\mu$ h		
L21	108-226	100 $\mu$ h		
L66	114-158	6-12 mh	Var.	Core not available separately
L70	114-158	6-12 mh	Var.	Core not available separately
L140	114-158	6-12 mh	Var.	Core not available separately
L143	108-204	3.9 mh		
L146	114-158	6-12 mh	Var.	Core not available separately

Resistors

Resistors are fixed, composition,  $\pm 10\%$  unless otherwise indicated.

R2	*310-561	120 $\Omega$	1/2 w	WW	1%
R4	*310-561	120 $\Omega$	1/2 w	WW	1%
R5	323-649	150 k	1/2 w	Prec.	1/2 %
R6	*310-561	120 $\Omega$	1/2 w	WW	1%
R8	*310-561	120 $\Omega$	1/2 w	WW	1%



## Resistors (Cont'd)

Ckt. No.	Tektronix Part. No.		Description			S/N Range
R12A	321-218	1.82 k	1/8 w		Prec.	1%
R12C	321-218	1.82 k	1/8 w		Prec.	1%
R12E	321-218	1.82 k	1/8 w		Prec.	1%
R12G	321-218	1.82 k	1/8 w		Prec.	1%
R12J	321-218	1.82 k	1/8 w		Prec.	1%
R12L	321-218	1.82 k	1/8 w		Prec.	1%
R12N	321-218	1.82 k	1/8 w		Prec.	1%
R12Q	321-218	1.82 k	1/8 w		Prec.	1%
R12S	321-218	1.82 k	1/8 w		Prec.	1%
R12U	321-218	1.82 k	1/8 w		Prec.	1%
R14	311-360	5 k		Var.		FINE
R14	311-0360-01	5 k		Var.		FINE
R16	321-239	3.01 k	1/8 w		Prec.	1%
R21	316-473	47 k	1/4 w			
R23	316-103	10 k	1/4 w			
R24	316-223	22 k	1/4 w			
R26	316-184	180 k	1/4 w			
R29	316-104	100 k	1/4 w			
R30A	323-289	10 k	1/2 w		Prec.	1%
R30A	323-0289-01	10 k	1/2 w		Prec.	1/2%
R30C	323-608	6 k	1/2 w		Prec.	1%
R30C	323-0608-01	6 k	1/2 w		Prec.	1/2%
R30E	323-222	2 k	1/2 w		Prec.	1%
R30E	323-0222-01	2 k	1/2 w		Prec.	1/2%
R30G	323-193	1 k	1/2 w		Prec.	1%
R30G	323-0193-01	1 k	1/2 w		Prec.	1/2%
R30J	323-607	600 Ω	1/2 w		Prec.	1%
R30J	323-0607-01	600 Ω	1/2 w		Prec.	1/2%
R30L	323-126	200 Ω	1/2 w		Prec.	1%
R30L	323-0126-01	200 Ω	1/2 w		Prec.	1/2%
R30N	323-097	100 Ω	1/2 w		Prec.	1%
R30N	323-0097-01	100 Ω	1/2 w		Prec.	1/2%
R30Q	323-606	60 Ω	1/2 w		Prec.	1%
R30Q	323-0606-01	60 Ω	1/2 w		Prec.	1/2%
R30S	323-030	20 Ω	1/2 w		Prec.	1%
R30S	323-0030-01	20 Ω	1/2 w		Prec.	1/2%
R30U	323-030	20 Ω	1/2 w		Prec.	1%
R30U	323-0030-01	20 Ω	1/2 w		Prec.	1/2%
R33	316-223	22 k	1/4 w			
R34	316-274	270 k	1/4 w			
R36	316-222	2.2 k	1/4 w			
R38	316-473	47 k	1/4 w			
R38	315-0473-00	47 k	1/4 w			5%
R39	316-274	270 k	1/4 w			
R39	315-0274-00	270 k	1/4 w			5%
R41	301-473	47 k	1/2 w			5%
R42	301-303	30 k	1/2 w			5%
R43	301-303	30 k	1/2 w			5%
R47	301-153	15 k	1/2 w			5%
R50	316-184	180 k	1/4 w			
R51	316-104	100 k	1/4 w			
R54	302-334	330 k	1/2 w			
R54	301-0334-00	330 k	1/2 w			
R55†	*311-417	5 k		Var.		5% VARIABLE

† Furnished as a unit with SW55.

Parts List — Type 3C66

Resistors (Cont'd)

Ckt. No.	Tektronix Part. No.		Description			S/N Range
R56	316-224	220 k	1/4 w			100-919
R56	315-0224-00	220 k	1/4 w		5%	920-up
R57	302-102	1 k	1/2 w			
R58	316-473	47 k	1/4 w			100-919
R58	315-0473-00	47 k	1/4 w		5%	920-up
R59	302-184	180 k	1/2 w			100-919
R59	301-0184-00	180 k	1/2 w		5%	920-up
R60	316-332	3.3 k	1/4 w			
R61	311-224	50 k		Var.		GAIN
R66	311-088	100 k	.2 w	Var.		NULL BAL
R71	316-105	1 meg	1/4 w			
R74	302-473	47 k	1/2 w			
R75	316-473	47 k	1/4 w			
R80	316-473	47 k	1/4 w			
R81	316-473	47 k	1/4 w			
R83	308-007	8 k	5 w		WW	5%
R85	311-156	200 k		Var.		POSITION RANGE
R88	311-147	10 k		Var.		PHASE
R89	316-153	15 k	1/4 w			
R91	323-636	50 k	1/2 w		Prec.	1%
R92	323-608	6 k	1/2 w		Prec.	1%
R93	316-154	150 k	1/4 w			
R94	316-395	3.9 meg	1/4 w			
R96	302-224	220 k	1/2 w			
R98	308-027	30 k	10 w		WW	5%
R99	316-104	100 k	1/4 w			
R101	316-104	100 k	1/4 w			
R105	302-393	39 k	1/2 w			
R109	304-183	18 k	1 w			
R111	316-104	100 k	1/4 w			
R112	316-104	100 k	1/4 w			
R125	302-104	100 k	1/2 w			
R128	301-104	100 k	1/2 w			5%
R129	301-683	68 k	1/2 w			5%
R133	302-473	47 k	1/2 w			
R136	315-471	470 Ω	1/4 w			5%
R147	316-473	47 k	1/4 w			
R148	315-222	2.2 k	1/4 w			5%
R149	302-103	10 k	1/2 w			
R150	316-472	4.7 k	1/4 w			100-1149
R150	315-0303-00	30 k	1/4 w			1150-up
R151	315-103	10 k	1/4 w			5%
R152	315-0104-00	100 k	1/4 w			5%
R153	311-183	500 k		Var.		POSITION X1540-up
R155	302-104	100 k	1/2 w			
R156	316-102	1 k	1/4 w			
R164	301-104	100 k	1/2 w			5%
R165	319-035	5 meg	1/4 w		Prec.	2%
R166	319-010	1.9 meg	1/4 w		Prec.	1%
R166	323-0510-00	2 meg	1/2 w		Prec.	1%
						100-1929
						1930-up

## Resistors (Cont'd)

Ckt. No.	Tektronix Part. No.		Description	Var.	S/N Range
R167	311-184	1 meg			SIG OUT DC LEVEL
R169	302-473	47 k	1/2 w		
R174	303-823	82 k	1 w		5%
R175	303-563	56 k	1 w		5%
R175	303-0513-00	51 k	1 w		5%
R176	301-0565-00	5.6 meg	1/2 w		5%
R178	303-823	82 k	1 w		5%
R190	316-101	100 $\Omega$	1/4 w		
R192	316-101	100 $\Omega$	1/4 w		
R194	316-101	100 $\Omega$	1/4 w		
R198	308-003	2 k	5 w	WW	5%

## Switches

	Unwired	Wired			
SW10A	} 260-566	*262-585	Rotary	{	EXT ARMS
SW10B					
SW11	260-288	*262-582	Rotary	{	CALIBRATE
SW12	260-565	*262-583	Rotary		CAPACITANCE
SW12	260-0565-01	*262-0583-00	Rotary		RESISTANCE
SW30	260-564	*262-584	Rotary		RESISTANCE
			Rotary		$\mu$ STRAIN/DIV
SW55†	*311-417		Rotary	{	CALIB
SW146A	} 260-563	*262-586	Rotary		FUNCTION
SW146B					

## Transformers

T84	*120-146	Oscillator
T110	*120-326	Demodulator

## Transistors

Q133	151-041	2N1303
------	---------	--------

## Electron Tubes

V24	154-043	12AX7	
V34	154-043	12AX7	
V54	154-043	12AX7	
V70	154-0022-01	6AU6	100-919
V70	154-0022-00	6AU6	920-up
V84	154-134	6CG7	
V94	154-257	7247	
V104	154-041	12AU7	
V124	154-257	7247	
V164	154-041	12AU7	
V174	154-041	12AU7	100-1149
V174	154-0187-00	6DJ8	1150-up

† Part of R55. Furnished as a unit.

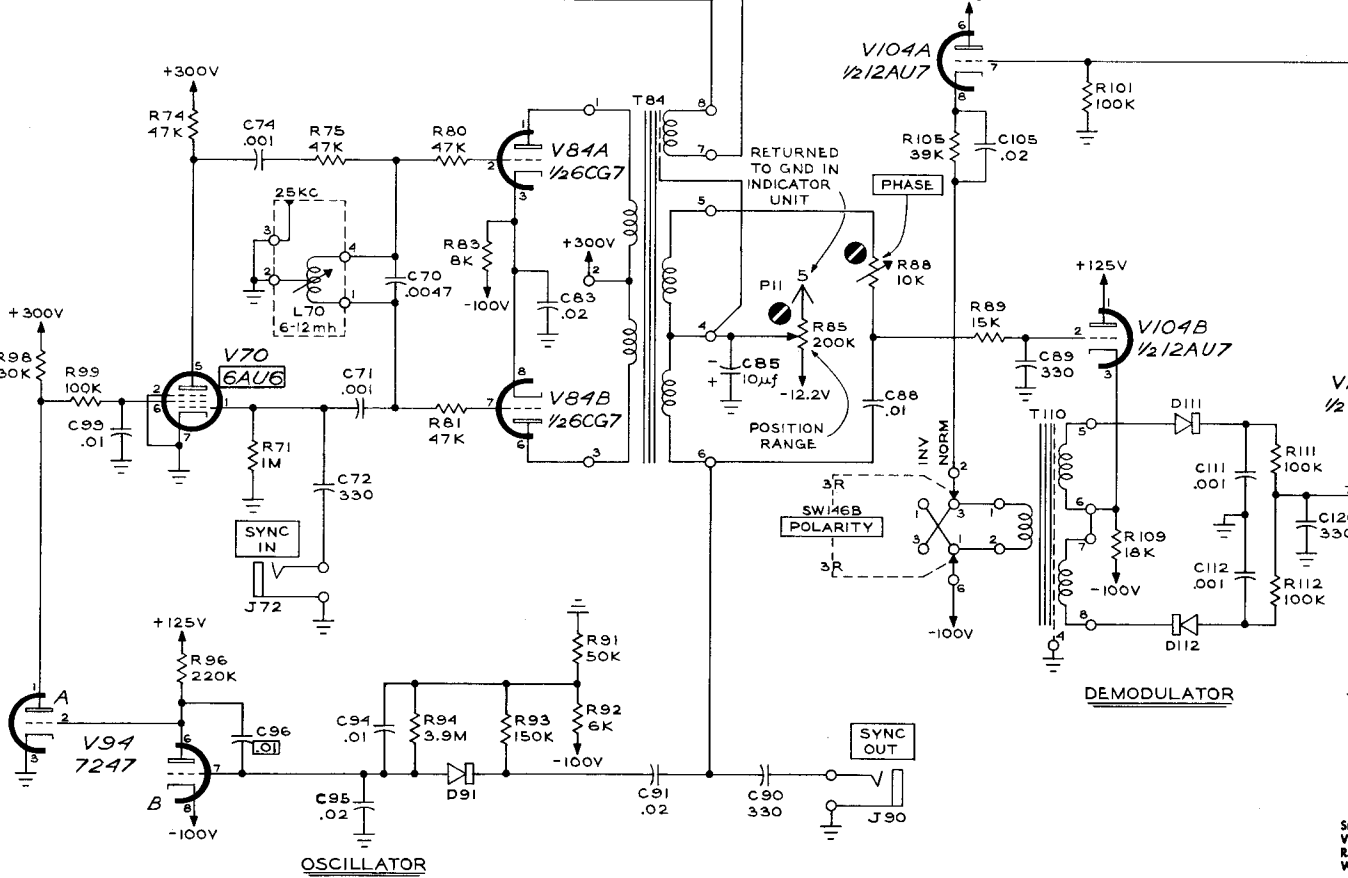
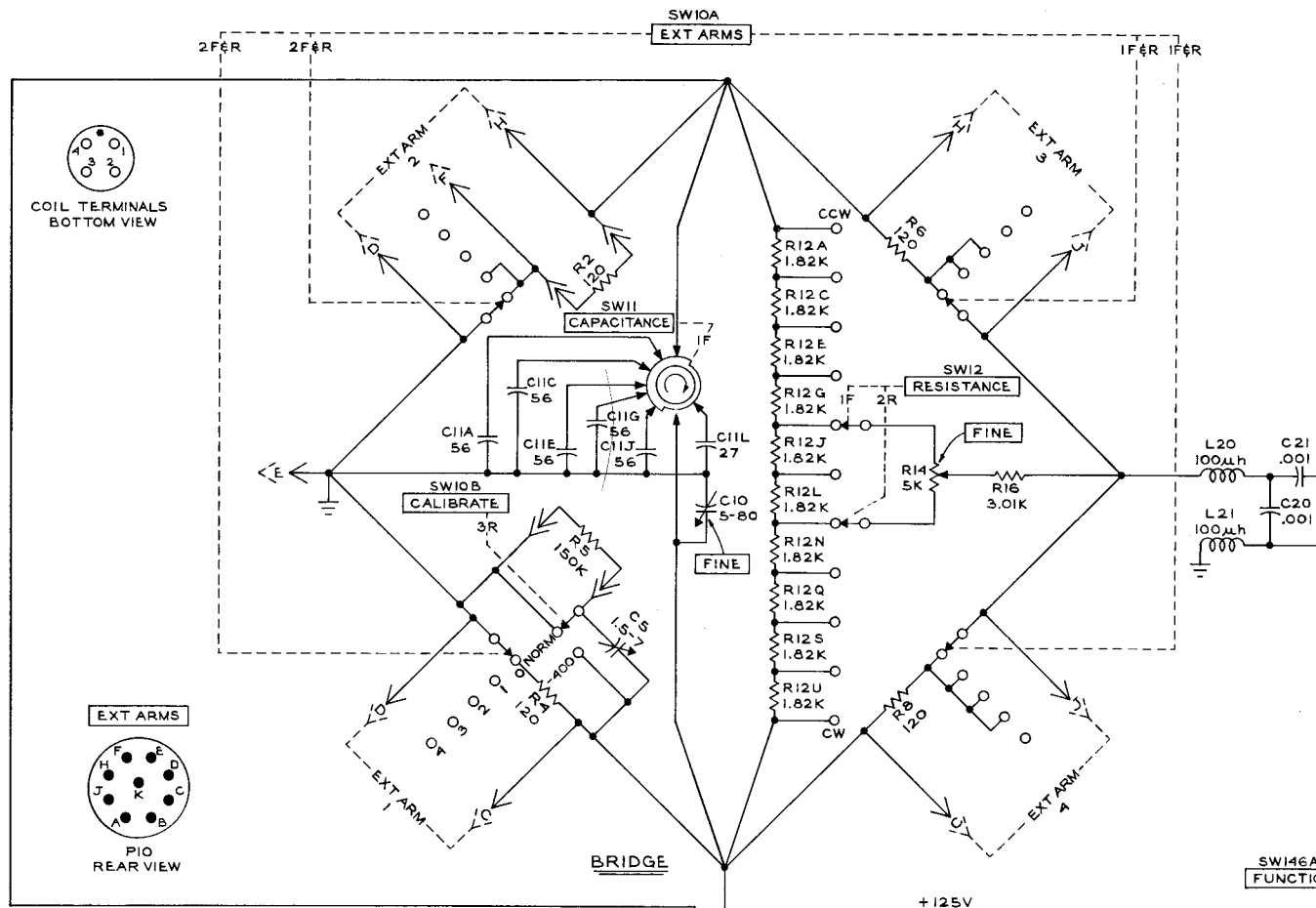

+

TYPE 3C66 PLUG-IN

H

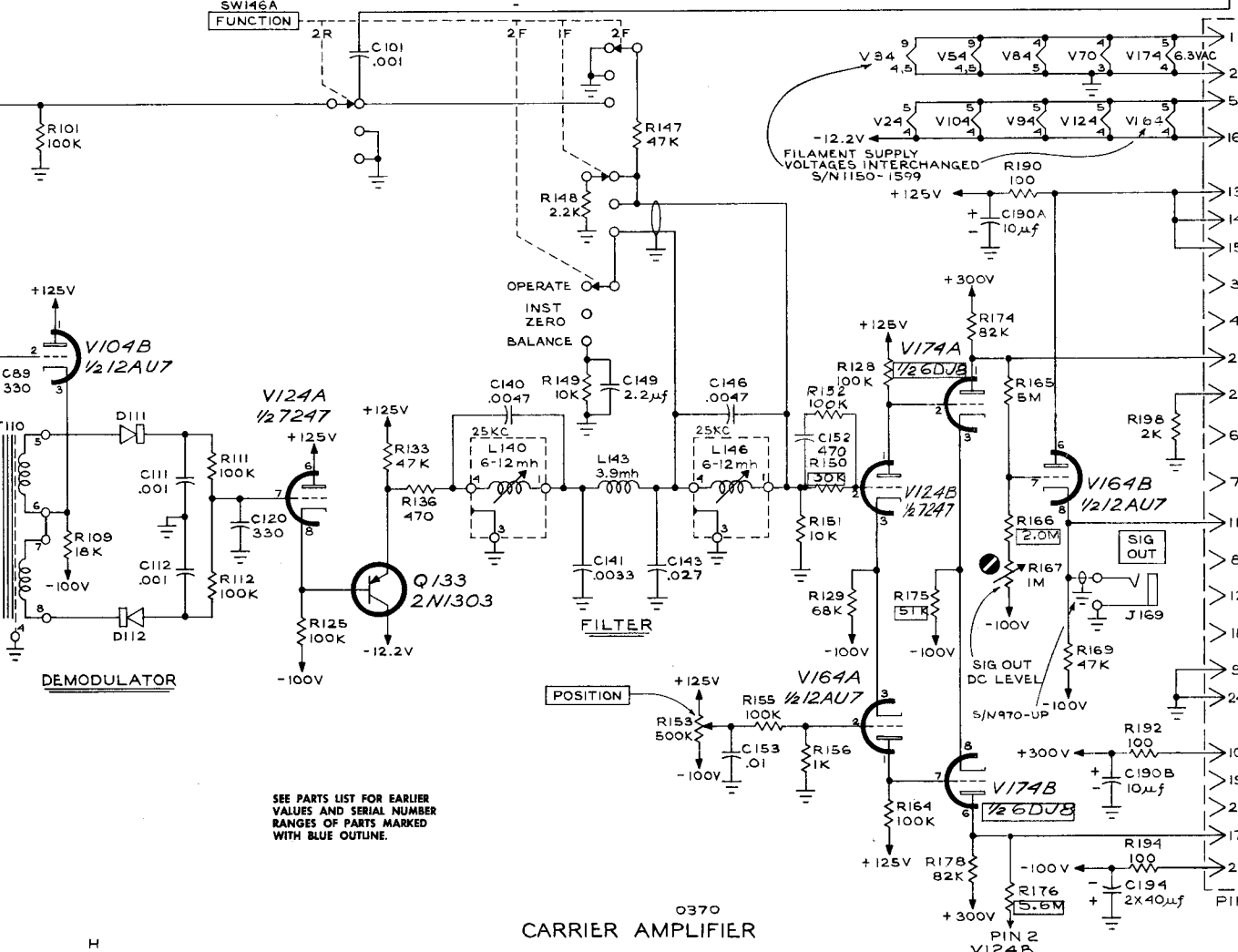
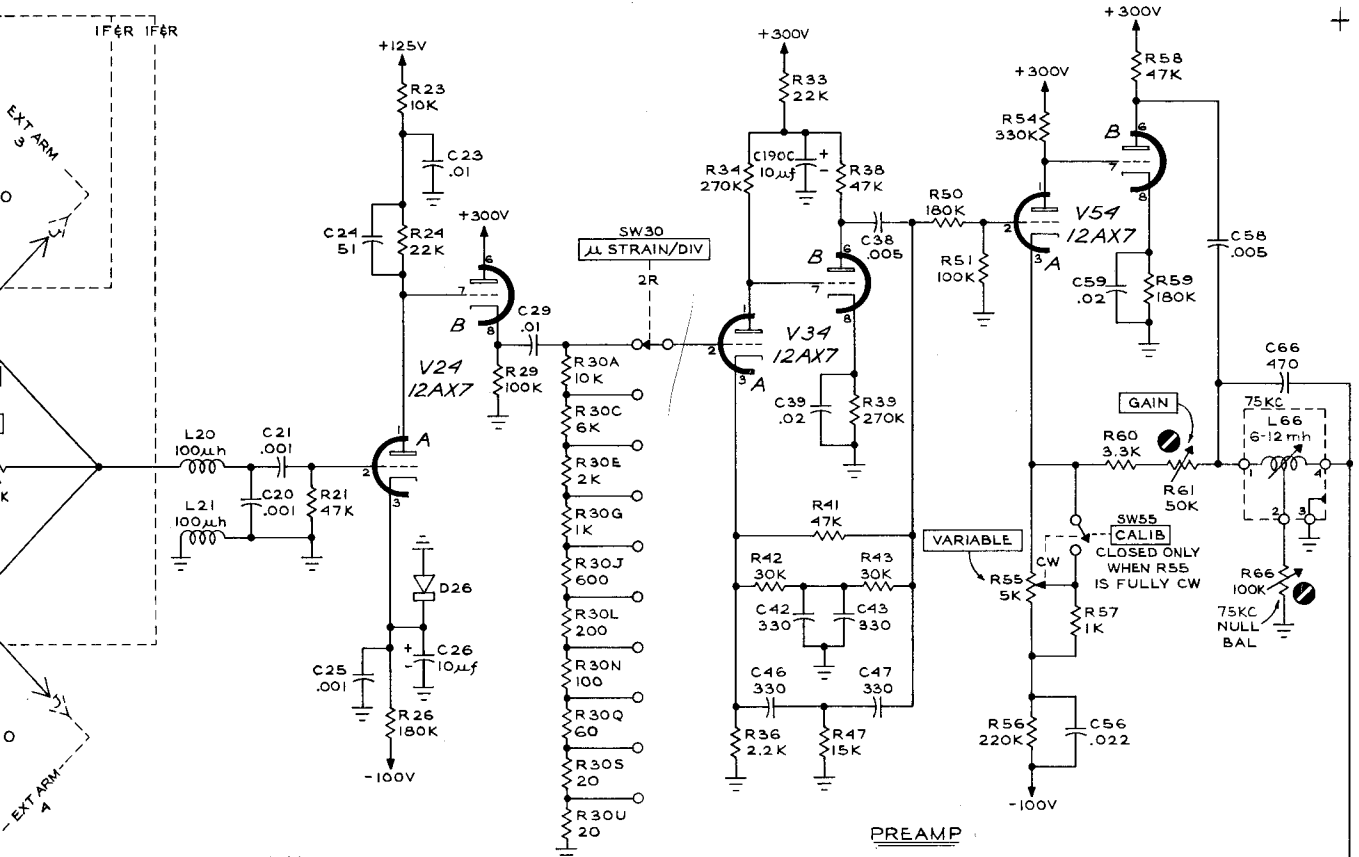

SEE PARTS LIST FOR EARLIER VALUES AND SERIAL NUMBER RANGES OF PARTS MARKED WITH BLUE OUTLINE.

0370  
CARRIER AMPLIFIER

## **MANUAL CHANGE INFORMATION**

At Tektronix, we continually strive to keep up with latest electronic developments by adding circuit and component improvements to our instruments as soon as they are developed and tested.

Sometimes, due to printing and shipping requirements, we can't get these changes immediately into printed manuals. Hence, your manual may contain new change information on following pages.

A single change may affect several sections. Sections of the manual are often printed at different times, so some of the information on the change pages may already be in your manual. Since the change information sheets are carried in the manual until ALL changes are permanently entered, some duplication may occur. If no such change pages appear in this section, your manual is correct as printed.